



LiteBrow™ Product Brochure

Suspended Polycarbonate Canopies





Contents

Company Overview 3

About LiteBrow™ 4

Innovative Technology 5

System Benefits 6

Planet Passionate 7

Kingspan Light + Air reserves the right to modify the design, change or discontinue products without prior written notice. The information contained in this brochure is based on data which are believed to be reliable, but no liability is assumed for any method or manner of use by the purchaser.

About Us

Who We Are

Kingspan Light + Air (KLA) is an award-winning innovator of daylighting solutions for high-performance building envelopes.

We are a pioneer and leader of the daylighting industry, and continually innovate so clients never have to choose between efficiency, style, and safety. And our focus on sustainability is instilled at every level of the company and at every step in the manufacturing process.

Our global team of highly-skilled and experienced professionals and extensive manufacturing capabilities make us a trusted partner in the ever-changing world of modern construction. Together, we leverage our knowledge and expertise to serve as one of the leading daylighting consultants for the architectural community and building industry.

Never Compromise. Always Innovate.

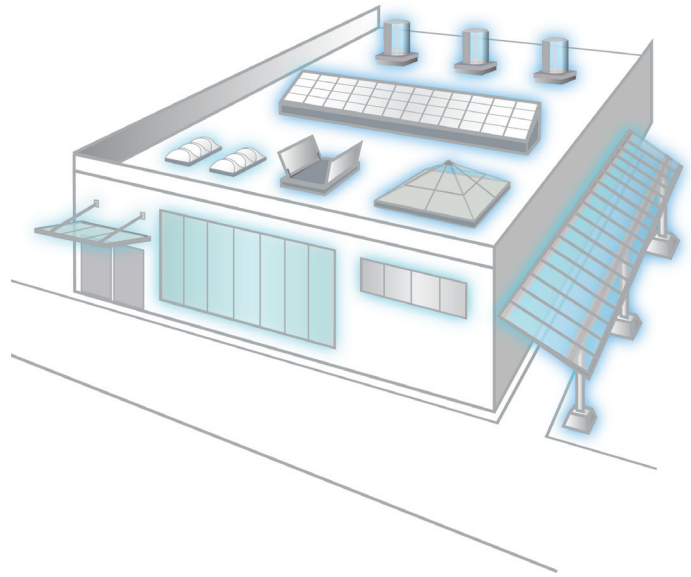

The KLA Advantage

You shouldn't have to compromise your design. We want to enable architects to achieve the highest levels of building performance without sacrificing aesthetics.

This is why we team up with architects, contractors, and building owners to develop the most versatile daylighting systems on the market. We will work with you from design concept through engineering and installation - and beyond - to ensure the highest levels of performance and quality.

Our expansive line-up of daylighting and natural ventilation solutions - from custom skylights and wall systems to tubular daylighting devices to canopies and small unit skylights - means that we can provide you with a system that fits your project's specific needs.



LiteBrow™ Canopies

Suspended Translucent Canopy System



A Sleek Alternative to Awnings and Sun Shades

LiteBrow™ suspended canopy systems are a pre-engineered, attached canopy system that ships fully assembled for ease of installation, with all necessary components included (structural components at the point of attachment to the building are required).

LiteBrow™ was designed to not only protect the front entrance of your building, but to also allow glare-free natural light into the adjacent space while limiting solar heat gain, creating a more pleasant and comfortable environment for occupants. Traditional systems like opaque awnings and sun shades are designed to block out the light, leaving these spaces cast in shadow.

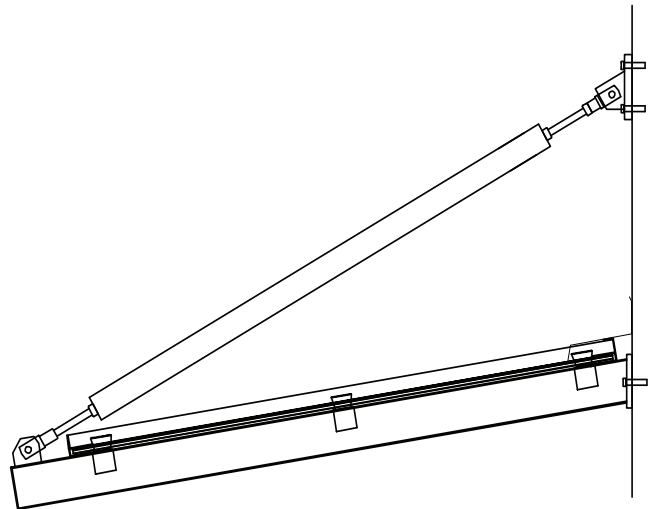

Standard LiteBrow Sizes

These canopies are available in 5x4, 5x8, and 5x12 units.

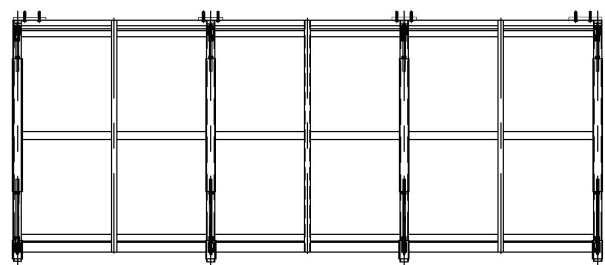
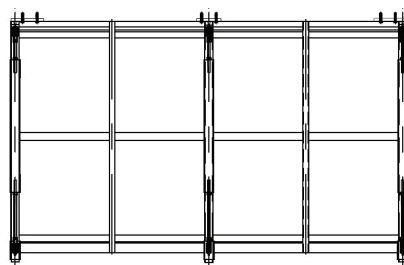
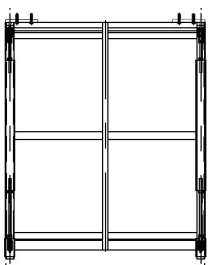

Our Innovative Technology

Glazing & Standing Seam Design

Our standing seam systems are designed to provide outstanding durability and excellent performance. The translucent glazing is precision engineered with Nano-Cell® technology. This specialized panel extrusion results in the cells measuring smaller than 0.18 inches, providing the panel with superior durability and prolonged resistance to impact. The unique cell structure significantly improves the quality and balanced distribution of glare-free natural light. Glazing panels are co-extruded with a specialized UV inhibitor on both sides of the panel.

Our panels are extruded with a permanent matte finish on the underside of the panel, which increases light diffusion, virtually eliminates glare, and maximizes visual comfort.

Key Components: Triple-Tooth Connection & Stainless Steel Panel Clip

The triple-tooth edge on the upstands of the glazing panels enables the system to withstand extremely high loads without concern for the panels disengaging. As the panels deflect, their grip on the u-shaped panel connector actually strengthens, ensuring long-term performance under loading conditions.

Our stainless steel panel clip is designed for heavy-duty performance, enabling the system to withstand high loading conditions and also maximizing the span between purlin supports.

Reverse Incline with Gutter at Wall

Typical units are designed to slope away from the building, but designers have the option to request a reverse incline which includes a gutter at the face of the wall.

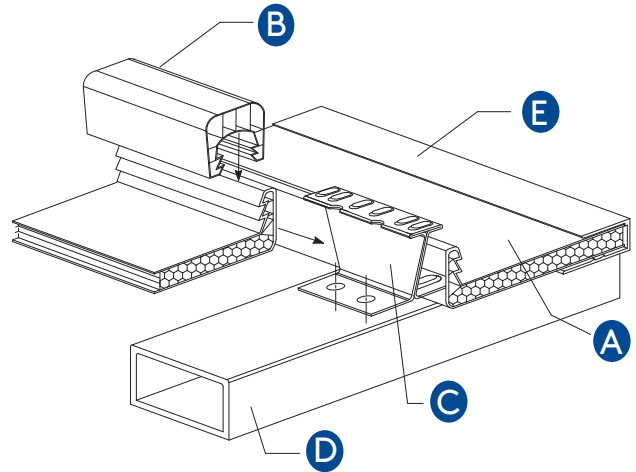
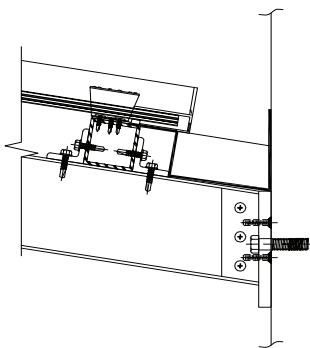

- A Glazing panel
- B Triple-tooth panel connector
- C Stainless steel panel clip
- D Aluminum purlin substructure
- E Aluminum framing system

*Monolithic polycarbonate systems also available - contact us for details

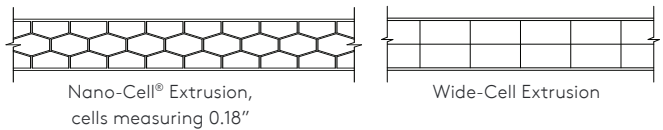

LiteBrow™ Canopies

Suspended Translucent Canopy System

Choose the System that Best Fits Your Needs - From Standard to Custom

LiteBrow™ suspended canopy systems are modular canopy units that are available in three standard sizes - 5ft x 4ft, 5ft x 8ft and 5ft x 12ft (custom sizes available) - and feature multi-cell or monolithic polycarbonate glazing.

LiteBrow™ canopy systems are extremely durable, and are available with a variety of options:

- Standing seam design with triple tooth-connection
- Co-extruded UV protection integrated within the panel for superior color stability
- Can utilize either tight-cell or monolithic polycarbonate glazing panels
- Clear monolithic polycarbonate can be an affordable alternative to glass glazing
- Translucent tight-cell extrusions offer increased durability and enhanced light diffusion
- Three standard sizes - 5ft x 4ft, 5ft x 8ft and 5ft x 12ft - with custom engineered systems also available
- Wide variety of standard color options - custom and matching also available

Not sure which configuration is right for your project? Contact our knowledgeable team to find out more about all LiteBrow™ options, and if a custom designed system is right for your canopy needs.



Wall Connections

Tie rods must be attached back to a structural component of the wall. Connections and fasteners will vary depending on building material. Contact us for project-specific details.

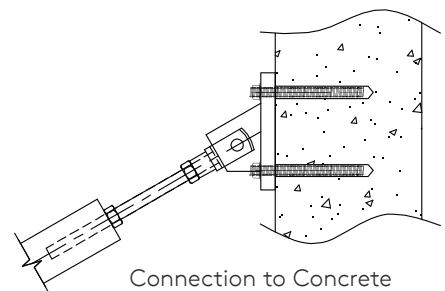
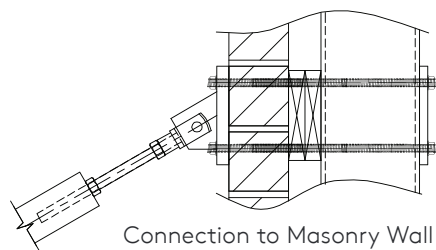
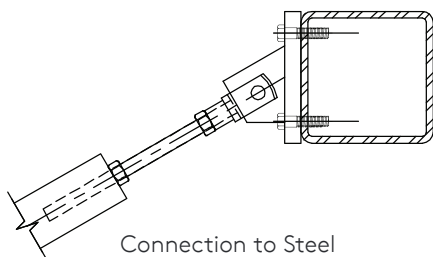



**WE ARE
PLANET
PASSIONATE**

ENERGY



CARBON



CIRCULARITY



WATER



At Kingspan, we want to play our part. We believe advanced materials, building systems and digital technologies hold the key to addressing these issues. Working in partnership with the industry, and through our new IKON innovation centre in Ireland and our Planet Passionate global sustainability program, we are confident that together we can:

1. Move to a clean energy future
2. Manage the earth's resources more sustainably
3. Protect our natural environment

What is Planet Passionate?

Planet Passionate is Kingspan's ambitious 10-year global sustainability program which aims to impact three global issues:

- Climate change
- Circularity
- Protection of our natural world

By setting ourselves challenging targets in the areas of energy, carbon, circularity and water, we aim to make significant advances in the sustainability of both our business operations and products.

Kingspan Light + Air

North American Headquarters

28662 N. Ballard Dr.

Lake Forest, IL 60045

Toll Free: +1 800 759 6985

T: +1 847 816 1060

F: +1 847 816 0425

E: info@kingspanlightandair.us

www.kingspanlightandair.us



To ensure you are viewing the most recent and accurate product information, please scan the QR code above

Care has been taken to ensure that the contents of this publication are accurate, but Kingspan Limited and its subsidiary companies do not accept responsibility for errors or for information that is found to be misleading. Suggestions for, or description of, the end use or application of products or methods of working are for information only and Kingspan Limited and its subsidiaries accept no liability in respect thereof.

For the product offering in other markets please contact your local sales representative or visit kingspan.com

© Kingspan and the Lion Device are Registered Trademarks of the Kingspan Group plc in the US, Canada and other countries.

© Kingspan Light + Air

MKT-BCH-0009-2402

