

# Cold Storage and Temperature Controlled Environments

Insulated Panels / Insulation Board / Insulated Doors



Kingspan, a global leader in high-performance building envelopes, has ideal solutions for thermally controlled environments such as cold storage freezers and coolers, food processing, and packaging facilities. In addition, Kingspan's controlled atmosphere solutions offer high value product protection and hygienic control.



---

## Consistent Temperature Control

Kingspan's diverse controlled environment product line has the highest insulation reliability for temperature extremes - from blast freezers as cold as -40°F (-40°C) to pharmaceutical stability rooms up to 200°F (93°C).

Kingspan offers fully integrated solutions, for a complete energy efficient thermal envelope, including walls, ceilings, under floor insulation, lighting and energy. From processing to warehousing to any application where thermal performance is critical, Kingspan is your ideal partner.



Scan here to connect to our digital brochure for updates.

---

## Kingspan CLEANsafe

In 2011, the U.S. Food & Drug Administration (FDA) implemented the U.S. Food Safety Modernization Act (FSMA) ensuring U.S. food supply safety by shifting from response of contamination to prevention. Kingspan initiated CLEANsafe, an industry first, engineered to comply with the FSMA – approved by the U.S. Department of Agriculture (USDA), FDA, the Food Safety and Inspection Service (FSIS), and the Canadian Food Inspection Agency (CFIA).

CLEANsafe insulated panels provide a sealed monolithic structure for maintaining hygiene safe requirements when exposed to secondary food contact and corrosive cleaning agents. The tight fitting panel joints offer superior airtightness, preventing thermal bridging and condensation.

Contact your Kingspan Sales Representative or our Technical Services Department with your specific building envelope requirements.

# 01

## Kingspan

Your Global Partner	4
It's all in the gray cells	6
Products at a Glance	8
Performance Benefits	10
Our Journey to Date	12
Planet Passionate	13
Kingspan Service	14
CLEANsafe	15
High Performance Color Coatings	17

# Products

## 02

### Wall Panel Systems

KS Shadowline	18
KS Shadowline Interior	19
KS Flat	20
KS Flat Interior	21
KS Azteco™	22
KS Micro-Rib	23
K-Roc™ HF Series	24

### Roof Panel Systems

KingRib 3 / KingRib 5	26
KingSeam Standing Seam	27

# 03

## Suspended Ceiling Assembly

Ceiling Tee	28
Standard Tee Support	28
Heavy Duty Tee Support	28
Concealed Ceiling Clip Assembly	29

# 04

## Construction Details

KS Shadowline Engaged Panel Joint	30
KS Shadowline Engaged Panel Joint	31
KS Shadowline Partition Base	32
KS Shadowline Partition Base	33
KS Shadowline Outside Corner Flush Trim	34
KS Shadowline Inside Corner Flush Trim	35
KS Shadowline Interior Partition to Exterior Wall	36
KS Shadowline Interior Rake with Membrane Roof	37
KS Shadowline Interior Wall to Ceiling Intersection	38
KS Shadowline Interior Ceiling Tee	39
KS Shadowline Ceiling Hidden Clip Wall to Roof	40
KS Shadowline Ceiling to all Longitudinal	41
KS Shadowline Ceiling to Wall Transverse	42

# 05

## Supplementary Products

Our Insulation Board Offerings	43
Controlled Environment Door Systems	44
Standard Product Line	45

# Your Global Partner

Kingspan is a global leader in the design, development and delivery of advanced building envelope products and solutions.

80+  
countries

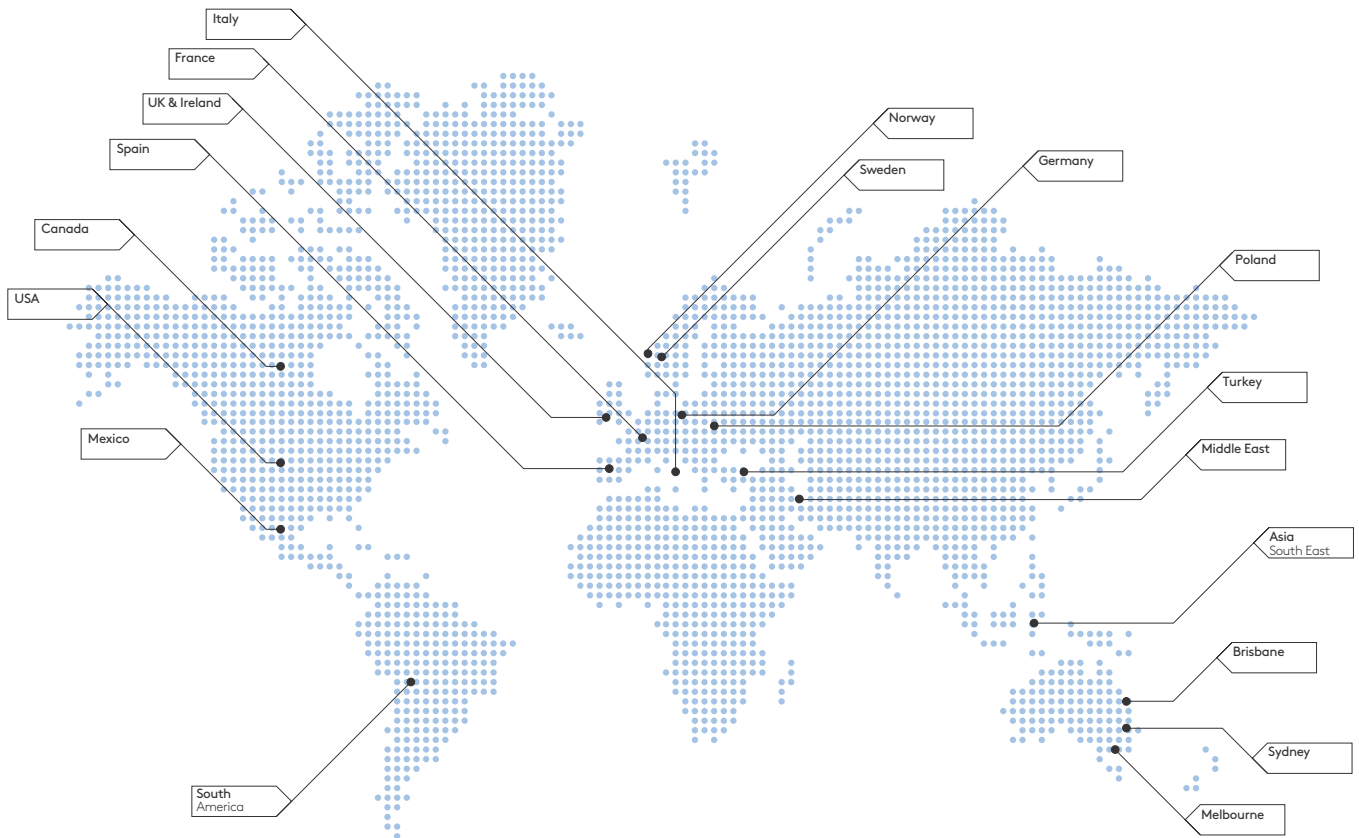

212+  
manufacturing  
sites worldwide

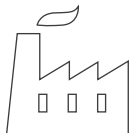

22,000+  
employees  
worldwide



---

At Kingspan Insulated Panels, we are pioneering better technologies and methods of building for a low carbon world. Improving building performance, construction methods and ultimately people's lives – that's what drives our people across the world. Energy efficiency is at the heart of our innovation, from making the industry's most thermally efficient core for our insulated panels, to producing the most airtight interfaces, to providing technical and field-service support on how to build optimally.

---

As the world demands more from buildings in terms of energy efficiency, fire safety, weather resilience, health and aesthetics, we have expanded beyond insulated panels in recent years to encompass high-end facades, smart LED lighting, integrated PV and structural steel solutions.

Together with the learnings from our ongoing research into better building design, these enhanced Kingspan envelopes will take our built environment to the next era of efficiency and wellbeing.



Higher Building Performance  
with Kingspan

# It's all in the gray cells

QuadCore® Technology is Kingspan's next generation of self-blended hybrid insulation core. Across the world of insulated panels, this innovation with its distinctive gray microcells powers the industry's highest combined performance:

- Unrivaled thermal efficiency
- Superior fire protection
- Unmatched health & wellness certification
- 30-year thermal warranty

QuadCore® Technology, together with our end-to-end services and whole building design know-how, takes Kingspan buildings to a higher level of lifetime performance, and delivers the ultimate protection for our partners, their buildings, and the environment for future generations.



POWERED BY  
**QuadCore**®  
TECHNOLOGY

# 1

## Unrivaled thermal efficiency

QuadCore® Technology is certified as one of the most thermally efficient closed-cell insulation core on the market.

### Lifetime performance and value benefits

- The class-leading R-value of R-8.0 per inch has the potential to reduce HVAC size, and lower both energy consumption and carbon emissions.
- QuadCore® Technology is a more streamlined solution relative to other insulation materials with associated benefits in interior space optimization, for specific transport, and ease of handling during construction.

# 2

## Superior fire protection

The hybrid nature of QuadCore® Technology delivers a range of improvements in fire performance which surpass all other insulated panel systems incorporating closed-cell insulation materials.

### Lifetime performance and value benefits

- For any building owner that wants the best protection against the impact of fire, the unique low smoke characteristics of QuadCore® Technology provide the optimum solution.
- QuadCore® Technology also delivers improved fire resistance ratings leading to more cost-effective installations due to economies in steelwork and fixing, in certain applications.

# 3

## Unmatched health & wellness certification

The improved thermal performance of QuadCore® Technology helps to optimize resource efficiency. It is also CFC, HCFC, HFC free and has a very low Global Warming potential.

### Lifetime performance and value benefits

- C2C Certified Material Health Certificate™ Silver
- Greenguard certified

# 4

## 30-year thermal warranty

The inimitable science behind QuadCore® Technology and comprehensive independent third-party testing has delivered the industry an unparalleled 30-year thermal performance warranty.

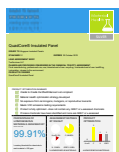

C2C Certified Material Health Certificate™ is a trademark of the Cradle to Cradle Products Innovation Institute.

# Products at a Glance

---

## Wall – Vertical and Horizontal Application

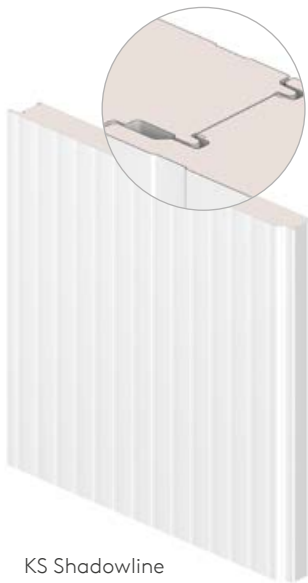



Roof

---

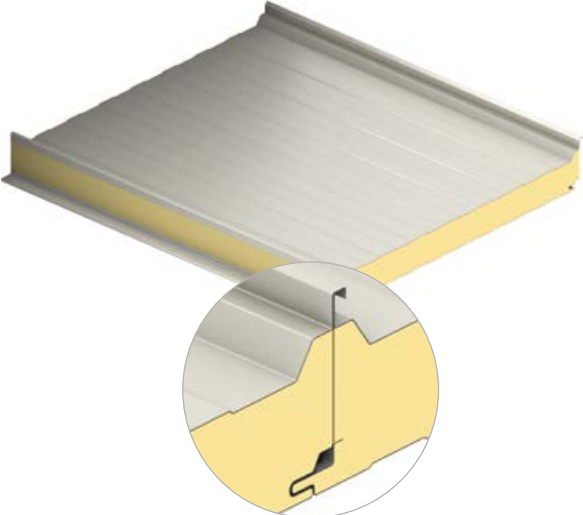

KingSeam®

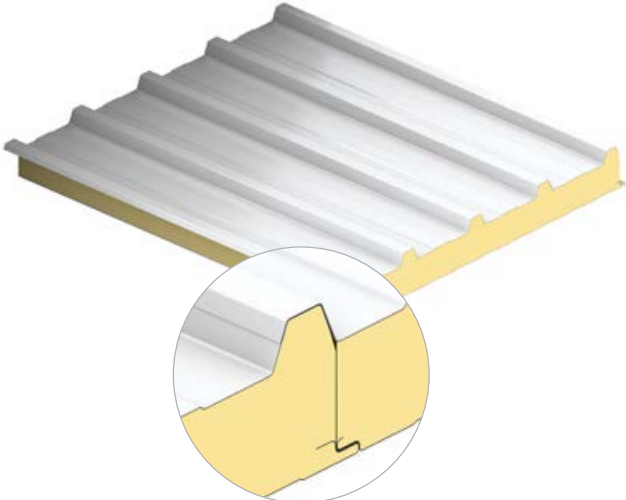

KingRib®

# Performance Benefits

---

Kingspan insulated panels are suitable for use within temperature controlled hygienic environments – where performance is critical.



---

## Precise Thermal Control

Ideally suited for environments where precise temperatures must be maintained. Panels are available in 2" through 6" thicknesses, for use in operating temperatures ranging from -40°F (-40°C) to 200°F (93°C).

---

## Superior Hygiene and High Performance Coatings and Liners

Kingspan's range of panels and coating systems (accepted by CFIA and USDA) resist moisture ingress and minimize potential for toxic mold or bacterial growth. Our tight-fitting tongue and groove interlocking joints allow for a completely washable surface, allowing strict hygienic control.



---

## Superior Airtightness and Weathertightness

One of the biggest sources of building heat loss (or heat gain) is due to air leakage i.e. – 'leaky buildings.' Kingspan insulated panels are rigorously tested to ensure that they remain both air and weathertight over the life of the building.



---

## High R-Value

Kingspan insulated panels' insulating cores provide superior thermal performance with tested R-values of 7.5 per inch nominal. Most importantly, the insulation is exterior of the building structure providing the best possible thermal envelope by reducing thermal bridging typical of cavity insulation systems. In addition, the panels feature excellent foam-to-foam contact, which provides an unbroken thermal shield against heat transfer.



---

## Faster Build

Kingspan insulated wall and roof panels provide the exterior weather barrier, high efficiency insulation core and an integral vapor barrier. This reduces multiple labor steps required with other envelope systems down to a single operation.

Kingspan insulated panels are available in a variety of cover widths with lengths of up to 52', making on-site handling and positioning easier while increasing installation productivity.



---

## Warranties

Kingspan insulated metal roof and wall panels have been used on every continent in the world under extreme climatic conditions and are manufactured from the highest quality materials, using state of the art production equipment to rigorous quality control standards, ensuring long-term reliability and service life.

Contact Kingspan for more information regarding our optional warranty programs.



Kingspan's single component systems can increase speed of build by up to **50%** compared to traditional multi-part systems.

# Our Journey to Date

In 2011, through our Net-Zero Energy programme, we committed globally to matching 100% operational energy with renewable energy by 2020.

We are on track to achieve this target through a three-pronged approach of Save More, Generate More and Buy More.

## Introducing Planet Passionate

Planet Passionate is our ambitious 10-year global sustainability programme that aims to impact three big global issues:

- **Climate change;**
- **Circularity; and**
- **Protection of our natural world.**

By setting ourselves challenging targets in the areas of energy, carbon, circularity and water, we aim to make significant advances in the sustainability of both our business operations and our products.

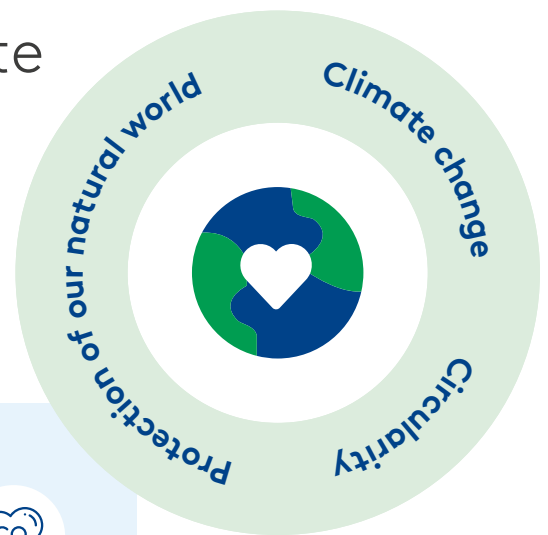

By being Planet Passionate in our operations we aim to:



Contribute to the world's renewable energy mix



Accelerate the shift to zero emission cars and reduce air pollution



Divert waste from landfill and keep materials in the economy



Reduce carbon emissions (including in our value chain)



Provide upcycling solutions for consumer plastic waste



Conserve precious water



Help to clean our oceans and protect wildlife

By being Planet Passionate our products will be:



Manufactured using **renewable energy** and harvested rainwater



Manufactured in **zero waste** facilities



Packaged in **recyclable** materials



Lower in **embodied carbon**



Containing **recycled materials** and recycled production waste



# Planet Passionate

Climate change is the single most important issue facing the world today. To protect our planet, we need to prevent a 1.5° rise in global temperatures this century.

To do this, carbon emissions need to be cut to net-zero globally by 2050, and the built environment has a key role to play in this challenge.

Today, buildings and construction together account for **36%** of global final energy use and **39%** of energy-related CO<sub>2</sub> emissions when upstream power generation is included.

## 1. Manufactured materials

**17%** of CO<sub>2</sub> emitted by all the products made for the global economy each year is attributable to building materials<sup>2</sup>

## 2. Global construction

The world's building stock is expected to **double** by 2060. However, **two thirds** of this new construction is in countries without mandatory building energy codes<sup>3</sup>

Embodied carbon will be responsible for half of the entire carbon footprint of new construction between now and 2050<sup>4</sup>

## 3. Buildings in use

**3.8 GtCO<sub>2</sub>** in emissions would be saved if all 2020 global building stock adopted high-performance envelope design measures<sup>5</sup>

This would account for approximately **10%** of all global CO<sub>2</sub> emissions

## 4. End of life

**70-80%** of global construction and demolition industry waste is discarded to landfill, accounting for approximately **30%** of all global waste to landfill<sup>6</sup>

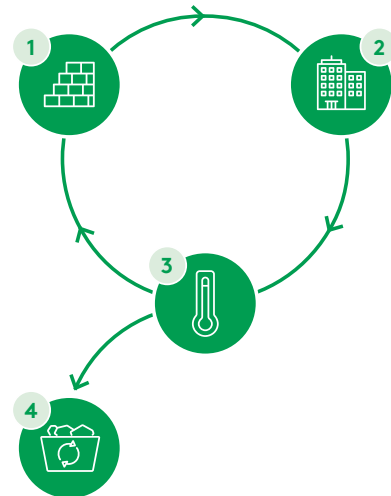

## Our approach to supporting global sustainability

At Kingspan, we want to play our part. We believe advanced materials, building systems and digital technologies hold the key to addressing these issues.

The products we make, powered by advanced proprietary Kingspan technologies, enable high-performance buildings that can save more energy and emit less carbon. Working in partnership with the industry, through our new IKON innovation centre and our Planet Passionate global sustainability programme, we are confident that together we can:

- **Move to a clean energy future;**
- **Manage the earth's resources more sustainably; and**
- **Protect our natural environment.**

In line with the UN Sustainable Development Goals, we will work with our partners and in collaboration with the industry to play our environmental footprint of our business and of the construction industry.

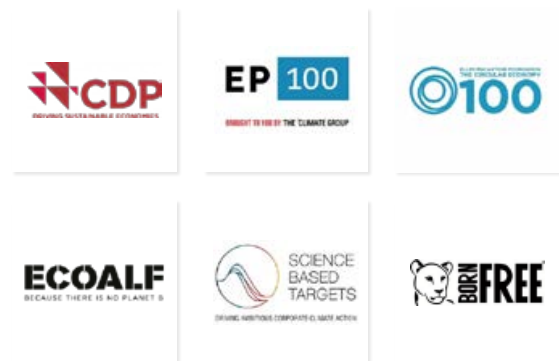

1. UN Global Status Report 2017 2. "The Circularity Gap Report", Circle Economy, 2019 3. IEA (2017), Energy Technology Perspectives 4. World Green Building Council 5. AECOM research based on UNEP Emissions Gap Report 2018 and UNEP Global Status Report 2017 6. Ellen MacArthur Foundation, World Economic Forum, The Boston Consulting Group 7. Figures relate to sales of Insulated Panels and Insulation Boards between 1993 and 2018

# Testing and Services – Kingspan Service

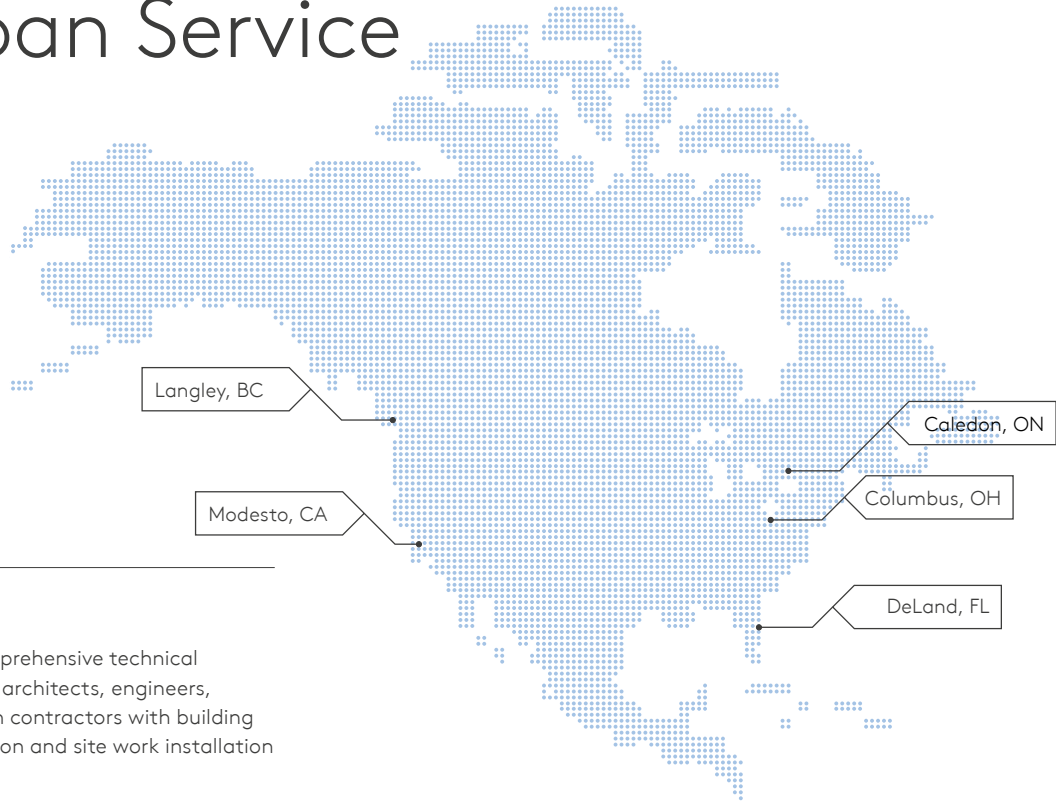

---

## Technical Service

Kingspan provides a comprehensive technical advisory service to assist architects, engineers, specifiers and installation contractors with building design, product application and site work installation training and challenges.

---

## Energy Service

Kingspan offers a performance energy modelling service on select projects to help design teams understand scenarios contributing to optimizing the energy efficiency of insulated metal panel assemblies based on meeting or exceeding ASHRAE 90.1 requirements.

---

## Customer Service

Our dedicated team provides focused customer service for all pre and post-order administration, delivery scheduling, and installer support, ensuring a seamless coordinated customer experience.

---

## Marketing Support

Our marketing team aims to provide a fast turnaround on standard sample and literature requests, eliminating delays with planning and client approval of material, so that your project begins on time.

Additional marketing support is provided through the use of project case studies.

---

## Field Service Support

Kingspan's Field Service Engineering Team offer customers free contractor training on the installation of new and existing products, site inspection services as well as advice on mechanical handling solutions.

---

## Sales Team

Our regionally based sales team can provide assistance on any project from the design stage through to site installation.

Find your local sales rep on our website [www.kingspanpanels.com](http://www.kingspanpanels.com)

---

## Email Us

Technical services:	<a href="mailto:technical.NA@kingspanpanels.com">technical.NA@kingspanpanels.com</a>
Installation seminars:	<a href="mailto:installation@kingspanpanels.com">installation@kingspanpanels.com</a>
Marketing:	<a href="mailto:marketingdept@kingspanpanels.com">marketingdept@kingspanpanels.com</a>
Product samples:	<a href="mailto:samples.NA@kingspan.com">samples.NA@kingspan.com</a>

Follow Kingspan on:



# CLEANSafe

Controlled environments take many different forms. Their performance and functionality depend on their specific project requirements and can be affected by the conditions the materials' systems are subjected to.

## Kingspan CLEANsafe

The corrosive factors of an internal environment are determined by the presence of corrosive chemicals and / or microorganisms in the internal atmosphere and relative humidity, as well as by the frequency of cleaning, aggressiveness of the cleaners, degreasers, sanitizers, and method of cleaning.

Kingspan CLEANsafe coatings, each designed specifically for temperature controlled environments, have particular properties suited to different environments. We offer and aid in choosing the right coatings to meet the appropriate classification of corrosive environment and type of activities.



	Corrosiveness	Inspection Frequency	Type of Application	Kingspan CLEANsafe MP	Kingspan CLEANsafe PVDF	Kingspan CLEANsafe120	Kingspan CLEANsafe Stainless Steel
C1	Very Low	Annually	Dry packaged cold storage, docks, locker rooms, toilets, offices, shops.	Yes	Yes	Yes	Yes
C2	Low	Annually	Storage, sorting and packing of fruit and vegetables, storage of packaged meat and dairy products.	-	Yes	Yes	Yes
C3	Medium	Every 6 months	Food production and preparation areas, dry process, ice cream production, butter production, breweries, dairies, wine cellars, processing of precooked foods, baking facilities	-	Yes	Yes	Yes
C4	High	Every 3 months	Wet process industrial kitchens and cooking, storage of unpacked fish, cheese, meat cutting, scalding and evisceration	-	-	Yes	Yes
C5	Very High	Every 3 months	Primary live rooms, rendering, picking, cooking, preparation of marine products	-	-	-	Yes

\*Buildings may contain areas where different conditions apply and must be considered separately if they have different corrosive environments. This table is provided for general guidance only. For more information about the effects of various chemicals on the coatings please contact your Kingspan Sales Rep or Kingspan Technical Services.

# CLEANSafe

## CLEANSafe

### Modified Polyester

CLEANSafe is a chemically inert polyester paint applied to pre-treated metal specifically developed for controlled environments.

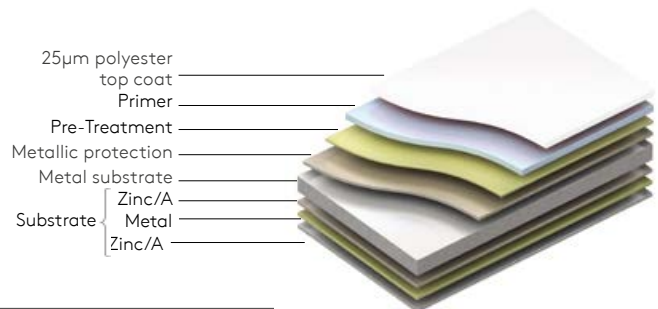

## CLEANSafe

### PVDF

CLEANSafe is a chemically inert polyester (PE) coating, applied to pre-treated metal, suitable for moderately aggressive internal environments.

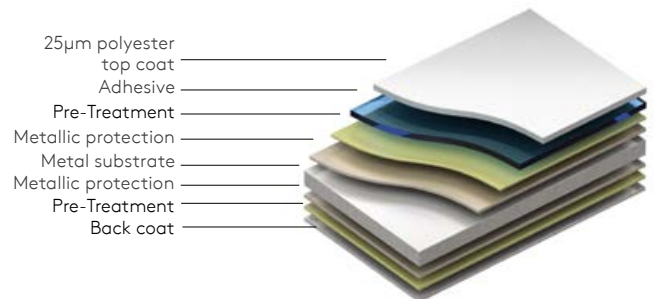

## CLEANSafe 120

CLEANSafe 120 is a chemically inert polyvinyl chloride (PVC) film, laminated to pre-treated metal, suitable for internal for controlled environments.

Joints between panels can be either caulked or chemically cold-welded.

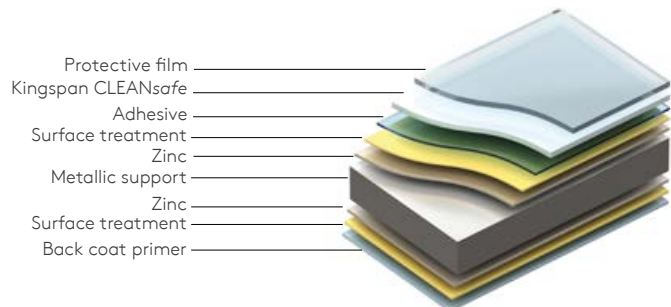

## CLEANSafe 304

### Stainless Steel

CLEANSafe Stainless steel 304 is a chemically inert, gap-free austenitic stainless steel, specifically designed for conditioned environments and environments with a high corrosion factor.





# High Performance Color Coatings

## Standard Colors

### MP (Modified Polyester)

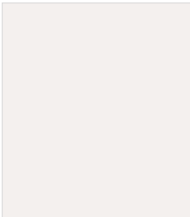

Imperial White  
SR:0.62 E:0.86 SRI:74

### SMP (Siliconized Modified Polyester)



Driftwood  
SR:0.55 E:0.86 SRI:64

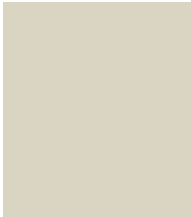

Sandstone  
SR:0.49 E:0.86 SRI:56

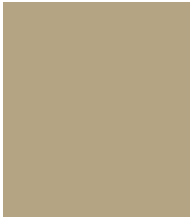

Surrey Beige  
SR:0.41 E:0.86 SRI:45

### Solid Fluoropon PVDF Colors – Kynar 500 / Hylar 5000

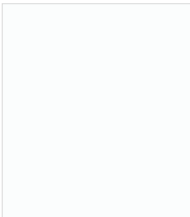

Regal White  
SR:0.70 E:0.86 SRI:85



Driftwood  
SR:0.45 E:0.86 SRI:50

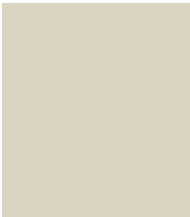

Sandstone  
SR:0.61 E:0.85 SRI:72

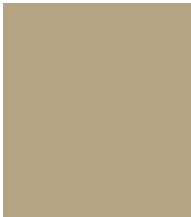

Surrey Beige  
SR:0.48 E:0.86 SRI:54

## Panel Interior

### Modified Polyester (MP)

(standard for facing, optional for exterior facing)  
A high-performance 2-coat system with cost effective resistance to environmental weathering, offering remarkable color, gloss retention, and chalk resistance. A 1.0 mil top coat USDA, CFIA accepted for food contact areas.

## Flurothane Coastal PVDF

This is a premium Fluoropolymer (PVDF) system developed for use in the most extreme coastal environments (less than 1500 feet from the coastline). The unique aspect about this system is the innovative thick film primer. This is field-proven and provides a high performance exterior finish delivering outstanding resistance to ultraviolet rays.

## KS Shadowline

KS Shadowline is the go-to panel for controlled environment needs. KS Shadowline Exterior Panels are ideal for use on Food Distribution and Cold Storage Warehouse facilities.

<b>Insulation Core:</b>	QuadCore® Technology
<b>Profile:</b>	Exterior: Shadowline Interior: Shadowline
<b>Embossing:</b>	Exterior: Stucco or non-embossed Interior: Stucco or non-embossed
<b>Gauge:</b>	Exterior: 26, 24, 22 ga Interior: 26, 24, 22 ga
<b>Width:</b>	24", 30", 36", 42"
<b>Thickness:</b>	2", 2.5", 3", 4", 5", 6"
<b>Length:</b>	8' - 53'
<b>Standard reveal options:</b>	Vertical: 1/8" or 3/8" Horizontal: 3/8"
<b>Orientation:</b>	Vertical or Horizontal
<b>Post fabrication:</b>	Trimless ends, folded corners (Manufacturing Limitations apply. Please contact us for detailed information)
<b>R-value:</b>	QuadCore® Technology: ≈ 8 per inch per ASTM C518 @ 75°F mean temperature ≈ 9 per inch per ASTM C518 @ 35°F mean temperature

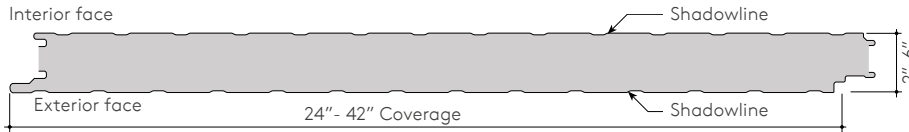

### KS Shadowline Interior

KS Shadowline Interior panels are applicable for both wall and ceiling conditions in cold storage buildings, food and meat processing plants, critical temperature and controlled environment areas as well as in medical and pharmaceutical facilities. The superior engineered joint assures a tight, well designed vapor barrier in enclosures of any size.

<b>Insulation Core:</b>	QuadCore® Technology
<b>Profile:</b>	Exterior: Shadowline Interior: Shadowline
<b>Embossing:</b>	Exterior: Stucco or non-embossed Interior: Stucco or non-embossed
<b>Gauge:</b>	Exterior: 26, 24, 22 ga Interior: 26, 24, 22 ga
<b>Width:</b>	45 3/8"
<b>Thickness:</b>	2", 2 3/4", 3", 4", 5", 6", 8"
<b>Length:</b>	8' - 53'
<b>Orientation:</b>	Vertical
<b>R-value:</b>	≈ 8 per inch per ASTM C518 @ 75°F mean temperature ≈ 9 per inch per ASTM C518 @ 35°F mean temperature

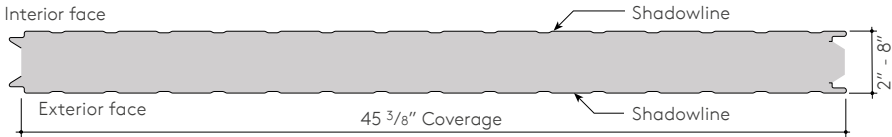

## KS Flat

KS Flat panels with QuadCore® are the ideal solution for interior walls and ceilings for a range of applications including food and life science, pharmaceutical, bio-technology laboratories, research and advanced technology facilities. KS Flat panels with QuadCore® offer the highest level of hygienic and contamination control.

KS Flat panels with QuadCore® feature a flat non-porous surface which aids cleaning and offers high levels of resistance to bacterial growth, ensuring a controlled, sterile environment.



<b>Insulation Core:</b>	QuadCore® Technology
<b>Profile:</b>	Exterior: Flat Interior: Shadowline
<b>Embossing:</b>	Exterior: Stucco or non-embossed Interior: Stucco or non-embossed
<b>Gauge:</b>	Exterior: 26, 24, 22 ga Interior: 26, 24, 22 ga
<b>Width:</b>	42"
<b>Thickness:</b>	2", 2.5", 3", 4", 5", 6"
<b>Length:</b>	8' - 53'
<b>Reveal option</b>	1/8" or 3/8"
<b>Orientation:</b>	Vertical or horizontal
<b>R-value:</b>	QuadCore® Technology: ≈ 8 per inch per ASTM C518 @ 75°F mean temperature ≈ 9 per inch per ASTM C518 @ 35°F mean temperature

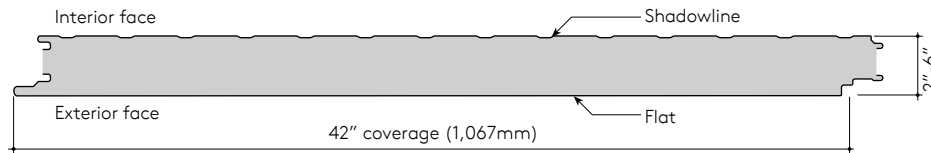

## KS Flat Interior

KS Flat Interior panels with QuadCore® are the ideal solution for interior walls and ceilings for a range of applications including food and life science, pharmaceutical, bio-technology laboratories, research and advanced technology facilities. KS Flat Interior panels with QuadCore® offer the highest level of hygienic and contamination control.

KS Flat Interior panels with QuadCore® feature a flat non-porous surface to both sides which aids cleaning and offers high levels of resistance to bacterial growth, ensuring a controlled, sterile environment.



<b>Insulation Core:</b>	QuadCore® Technology
<b>Profile:</b>	Exterior: Flat Interior: Shadowline or Flat
<b>Embossing:</b>	Exterior: Stucco or non-embossed Interior: Stucco or non-embossed
<b>Gauge:</b>	Exterior: 24, 22 ga Interior: 24, 22 ga
<b>Width:</b>	45 3/8"
<b>Thickness:</b>	2", 2 3/4", 3", 4", 5", 6", 8"
<b>Length:</b>	8' - 53'
<b>Reveal option:</b>	N/A
<b>Orientation:</b>	Vertical
<b>R-value:</b>	QuadCore® Technology: ≈ 8 per inch per ASTM C518 @ 75°F mean temperature ≈ 9 per inch per ASTM C518 @ 35°F mean temperature

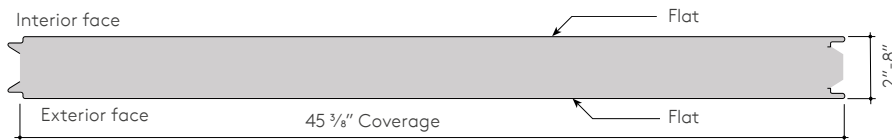

## KS Azteco™

KS Azteco™ panels have a flat exterior profile with a heavy embossed texture. Ideal for improving curb appeal and addressing community or municipal design restrictions.

<b>Insulation Core:</b>	QuadCore® Technology
<b>Profile:</b>	Exterior: Flat Interior: Shadowline
<b>Embossing:</b>	Exterior: Azteco Interior: Stucco or non-embossed
<b>Gauge:</b>	Exterior: 26, 24, 22 ga Interior: 26, 24, 22 ga
<b>Width:</b>	24", 30", 36", 42"
<b>Thickness:</b>	2", 2.5", 3", 4", 5", 6"
<b>Length:</b>	8' – 53'
<b>Standard reveal options:</b>	Vertical: 1/8" or 3/8" Horizontal: 3/8"
<b>Orientation:</b>	Vertical or horizontal
<b>Post fabrication:</b>	Trimless ends, folded corners (Manufacturing Limitations apply. Please contact us for detailed information)
<b>R-value:</b>	QuadCore® Technology: ≈ 8 per inch per ASTM C518 @ 75°F mean temperature ≈ 9 per inch per ASTM C518 @ 35°F mean temperature

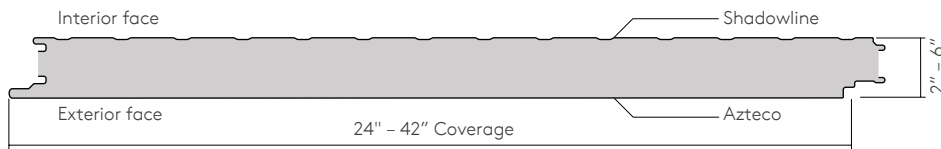

### KS Micro-Rib

Mirco-Rib wall systems create a highly attractive linear appearance with subtle shadows, providing design flexibility and architectural improvement to the traditional warehouse design.

<b>Insulation Core:</b>	QuadCore® Technology
<b>Profile:</b>	Exterior: Micro-Rib Interior: Shadowline
<b>Embossing:</b>	Exterior: Stucco or non-embossed Interior: Stucco or non-embossed
<b>Gauge:</b>	Exterior: 24, 22 ga Interior: 26, 24, 22 ga
<b>Width:</b>	24", 30", 36", 42"
<b>Thickness:</b>	2", 2.5", 3", 4", 5", 6"
<b>Length:</b>	8' – 53'
<b>Standard reveal options:</b>	Vertical: 1/8" or 3/8" Horizontal: 3/8"
<b>Orientation:</b>	Vertical or horizontal
<b>Post fabrication:</b>	Trimless ends, folded corners (Manufacturing Limitations apply. Please contact us for detailed information)
<b>R-value:</b>	QuadCore® Technology: ≈ 8 per inch per ASTM C518 @ 75°F mean temperature ≈ 9 per inch per ASTM C518 @ 35°F mean temperature

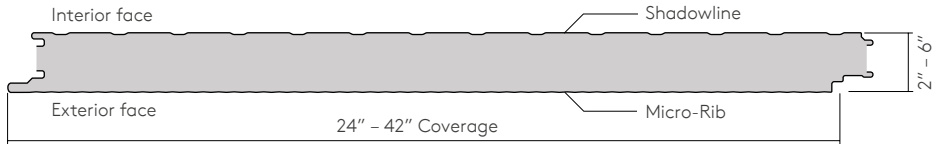

## K-Roc™ HF Series

For superior fire protection K-Roc HF Series panels are an excellent choice. The 42" cover width of K-Roc HF allows for fast, easy installation.

Note: In certain light duty structures, unique hidden fastener details may be available depending on spans, structural loads and climatic conditions (please contact Kingspan Technical Services for detailed advice prior to specification or bid).

<b>Insulation Core:</b>	Mineral fiber
<b>Profile:</b>	Exterior: Azteco™, Flat, Micro-Rib, Mini Micro-Rib, Shadowline Interior: Shadowline
<b>Embossing:</b>	Exterior: Stucco or non-embossed (Azteco™ profile only available with Azteco™ embossing) Interior: Stucco or non-embossed
<b>Gauge:</b>	See individual panels
<b>Width:</b>	42"
<b>Thickness:</b>	4", 6", 8"
<b>Length:</b>	8' - 48'
<b>Standard reveal options:</b>	1/8"
<b>Orientation:</b>	Vertical or horizontal
<b>Post fabrication:</b>	N/A
<b>R-value:</b>	4.0 per inch per ASTM C518 @ 75°F or 35°F mean temperature





**K-Roc HF Azteco™**

Gauge: Exterior: 24, 22 ga  
Interior: 26, 24, 22 ga

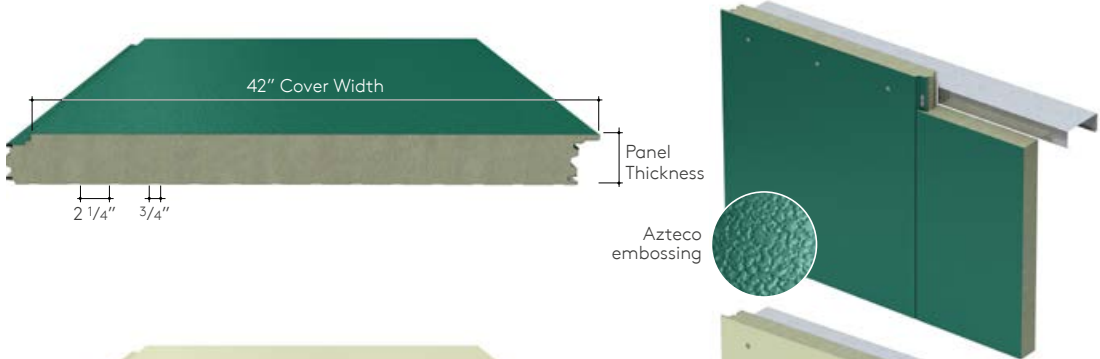

**K-Roc HF Flat**

Gauge: Exterior: 24, 22 ga  
Interior: 26, 24, 22 ga

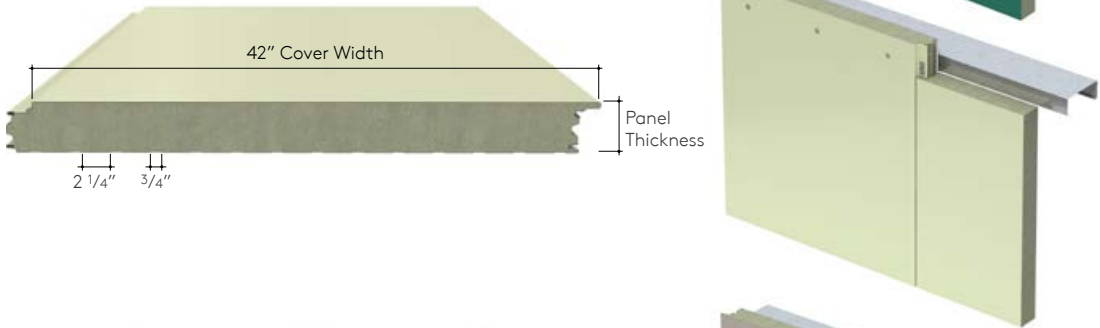

**K-Roc HF Micro-Rib**

Gauge: Exterior: 24, 22 ga  
Interior: 26, 24, 22 ga

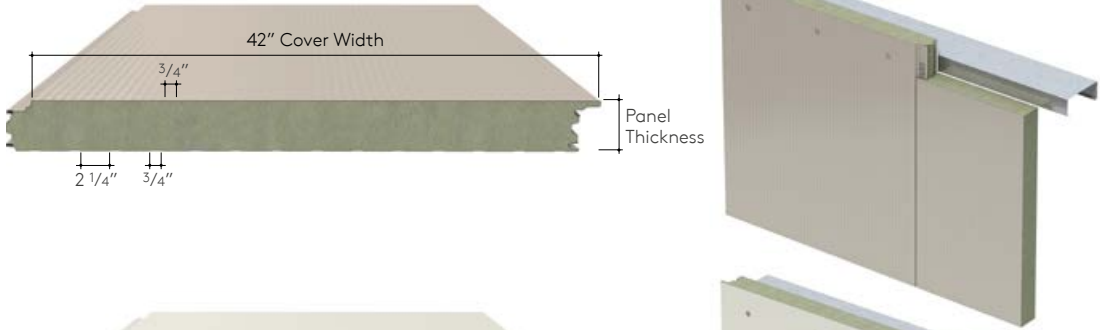

**K-Roc HF Mini Micro-Rib**

Gauge: Exterior: 24 ga  
Interior: 26, 24, 22 ga

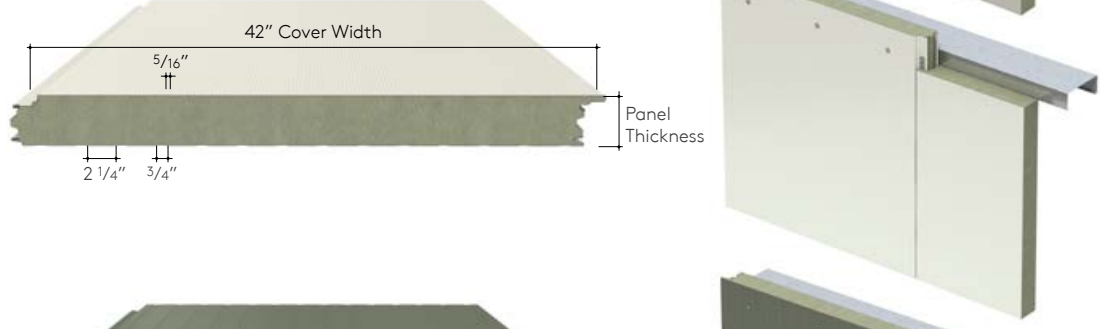

**K-Roc HF Shadowline**

Gauge: Exterior: 26, 24, 22 ga  
Interior: 26, 24, 22 ga

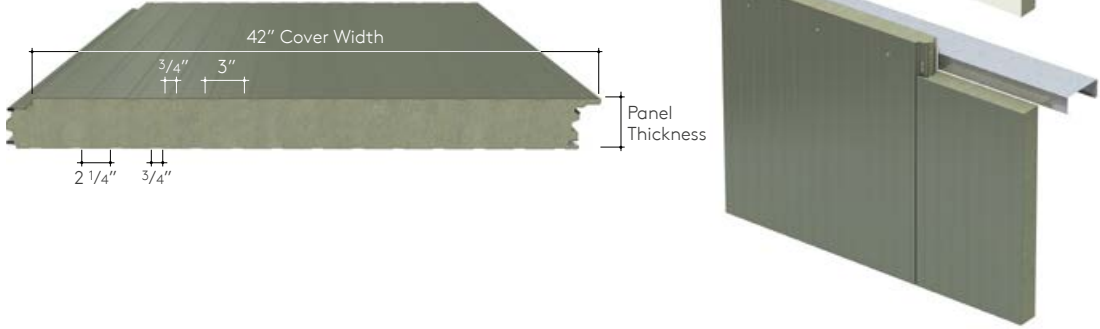

## KingRib 3 / KingRib 5

The KingRib insulated roof panel is the perfect option for a modern design combined with high energy-efficiency, durability, and high R-value. KingRib will not only enhance your building's aesthetic appeal, but will also dramatically improve the efficiency of your building's thermal envelope.

<b>Profile:</b>	Exterior: Mesa with Trapezoidal Ribs Interior: Mesa
<b>Embossing:</b>	Exterior: Stucco or non-embossed Interior: Stucco or non-embossed
<b>Gauge:</b>	Exterior: 26, 24, 22 ga Interior: 26, 24, 22 ga
<b>Width:</b>	40"
<b>Thickness:</b>	1.5", 2.5", 4", 5", 6"
<b>Length:</b>	8' - 50' (please contact your Kingspan Regional Sales Manager or Kingspan Technical Services for detailed limitations on specific lengths)
<b>Post fabrication:</b>	Cutbacks
<b>R-value:</b>	≈ 7.1 per inch per ASTM C518 @ 75°F mean temperature ≈ 8.1 per inch per ASTM C518 @ 35°F mean temperature



### KingRib 3

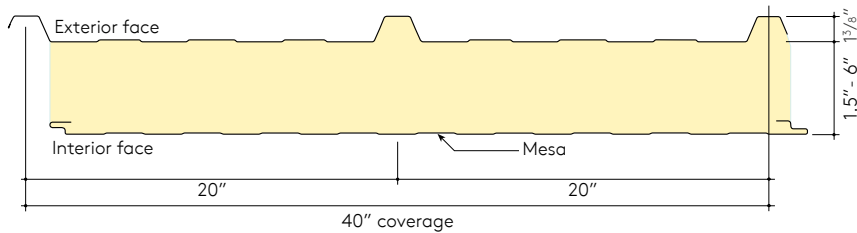

### KingRib 5

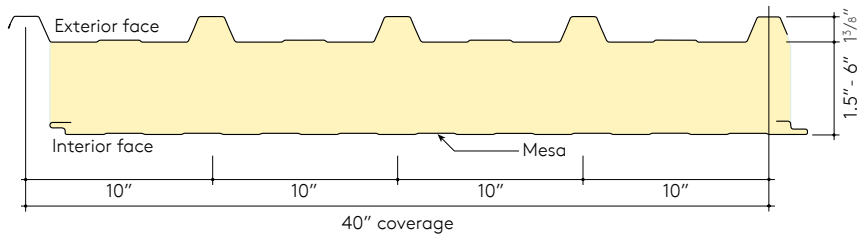

## KingSeam Standing Seam

KingSeam insulated standing seam roof panels are designed to offer design flexibility and aesthetics combined with high R-values and unparalleled service life performance. KingSeam is suitable for new and retrofit applications across commercial, industrial and institutional market sectors.

<b>Profile:</b>	Exterior: Mesa with Trapezoidal Ribs Interior: Mesa
<b>Embossing:</b>	Exterior: Non-embossed Interior: Stucco or non-embossed
<b>Gauge:</b>	Exterior: 26, 24, 22 ga Interior: 26, 24, 22 ga
<b>Width:</b>	40"
<b>Thickness:</b>	3.25", 4", 5", 6"
<b>Length:</b>	8' - 50' (please contact your Kingspan Regional Sales Manager or Kingspan Technical Services for detailed limitations on specific lengths)
<b>Post fabrication:</b>	Cutbacks at eaves and end laps
<b>R-value:</b>	≈ 7.1 per inch per ASTM C518 @ 75°F mean temperature ≈ 8.1 per inch per ASTM C518 @ 35°F mean temperature

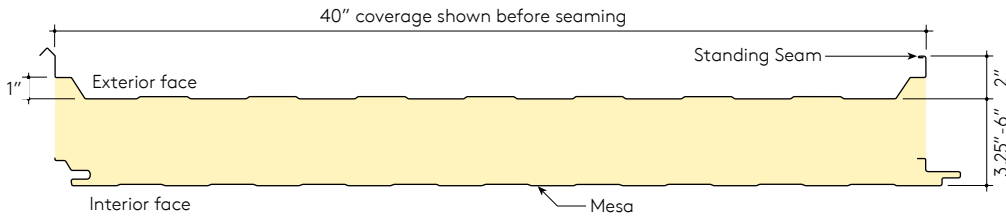

# Suspended Ceiling Assembly

## Ceiling Tee

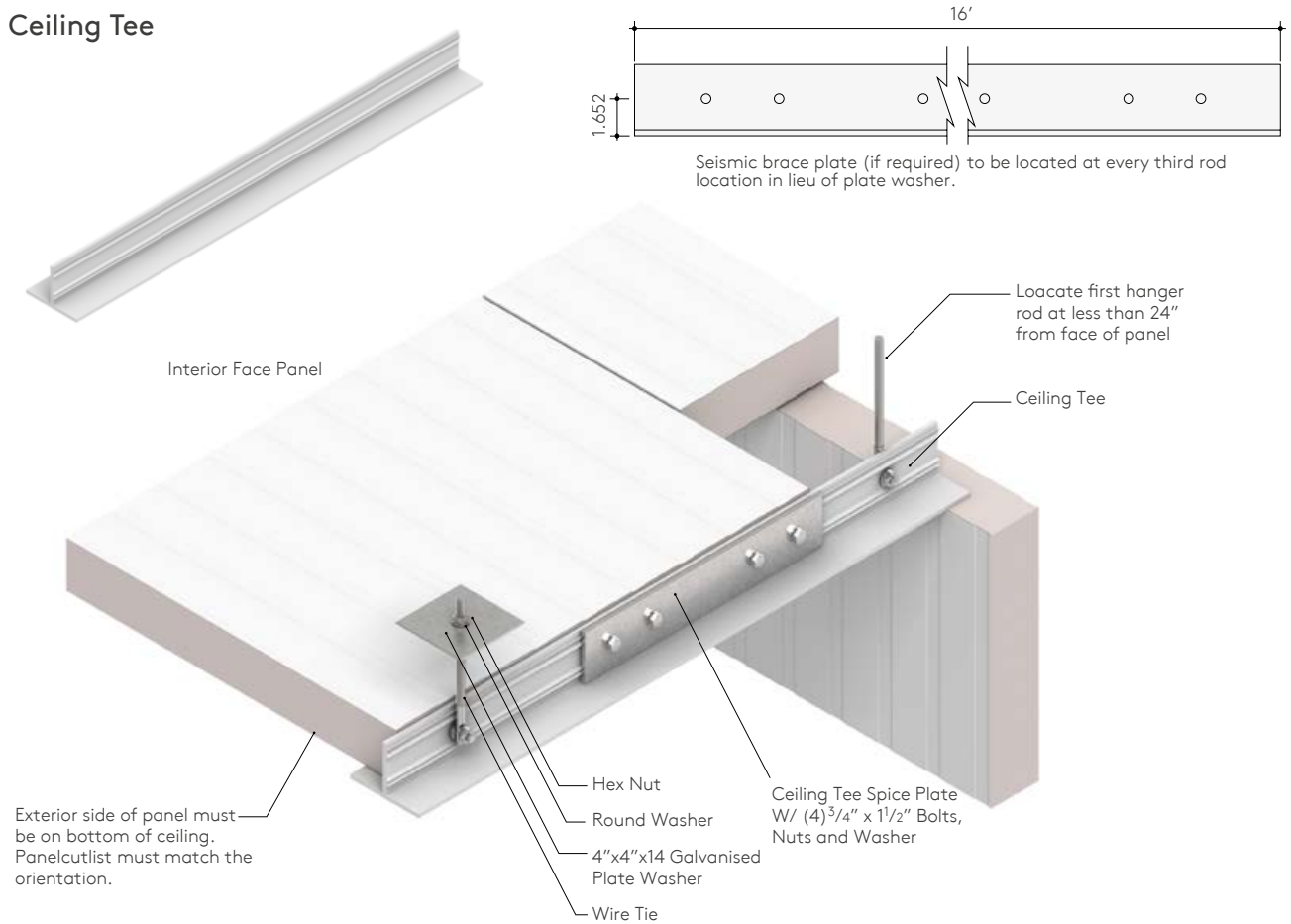

## Standard Tee Support

Designed for 10psf Non-Accessible load.  
6063-T6 Alloy  
Pre-drilled  
16'-0" White and Bare Options

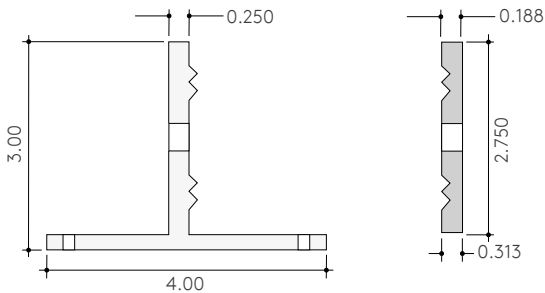

## Heavy Duty Tee Support

Designed for 25psf Accessible and Walkable.  
6063-T6 Alloy  
Pre-drilled  
16'-0" White and Bare Options

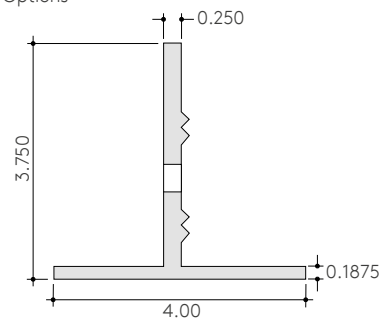

# Suspended Ceiling Assembly

## Concealed Ceiling Clip Assembly

Tested 25psf Walk on design @ 6'0" Rod Spacing

Standard 10psf non-accessible at 12'-0" Rod Spacing

Supplemental to any Tee Support system for flexibility and project restraints.

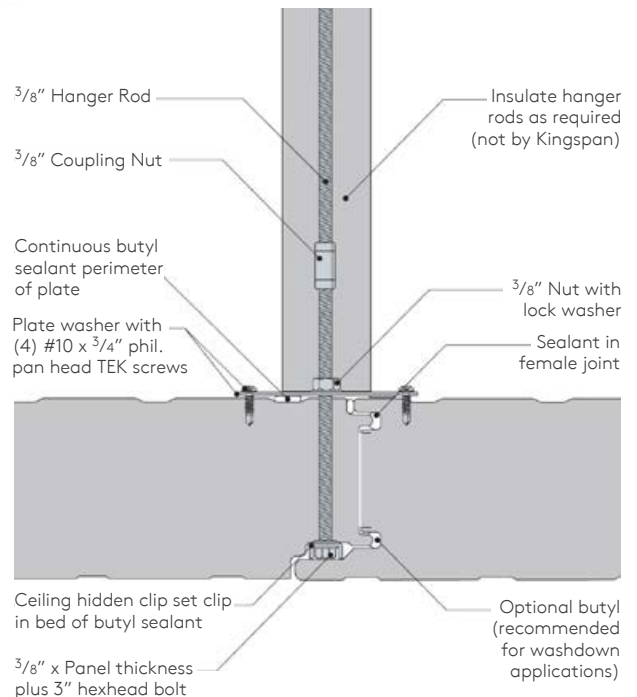
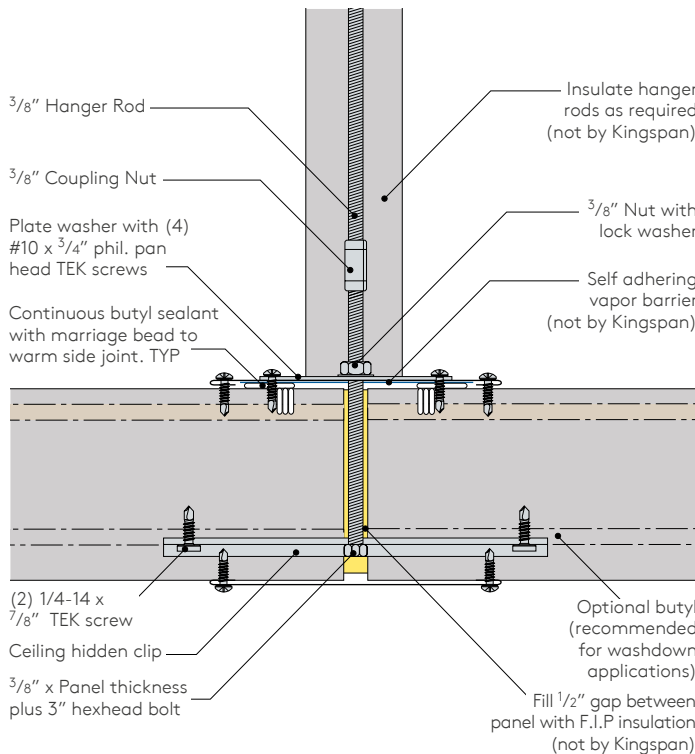
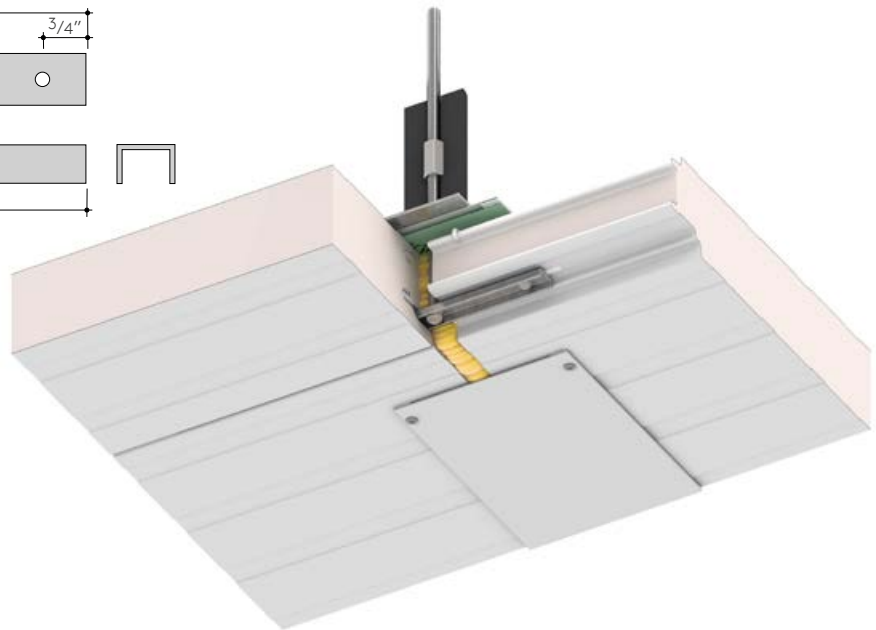
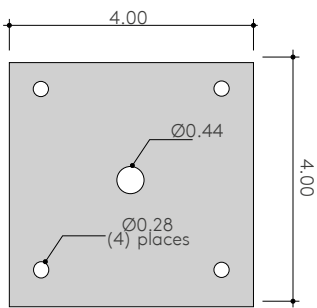
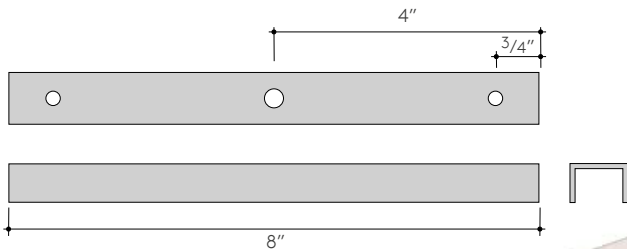

# Construction Details

## KS Shadowline Engaged Panel Joint

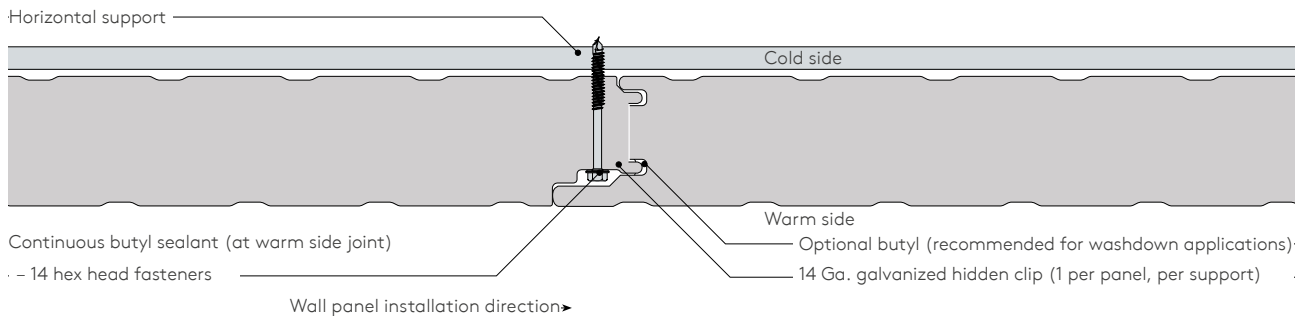

# Construction Details

## KS Shadowline Base with Insulated Slab

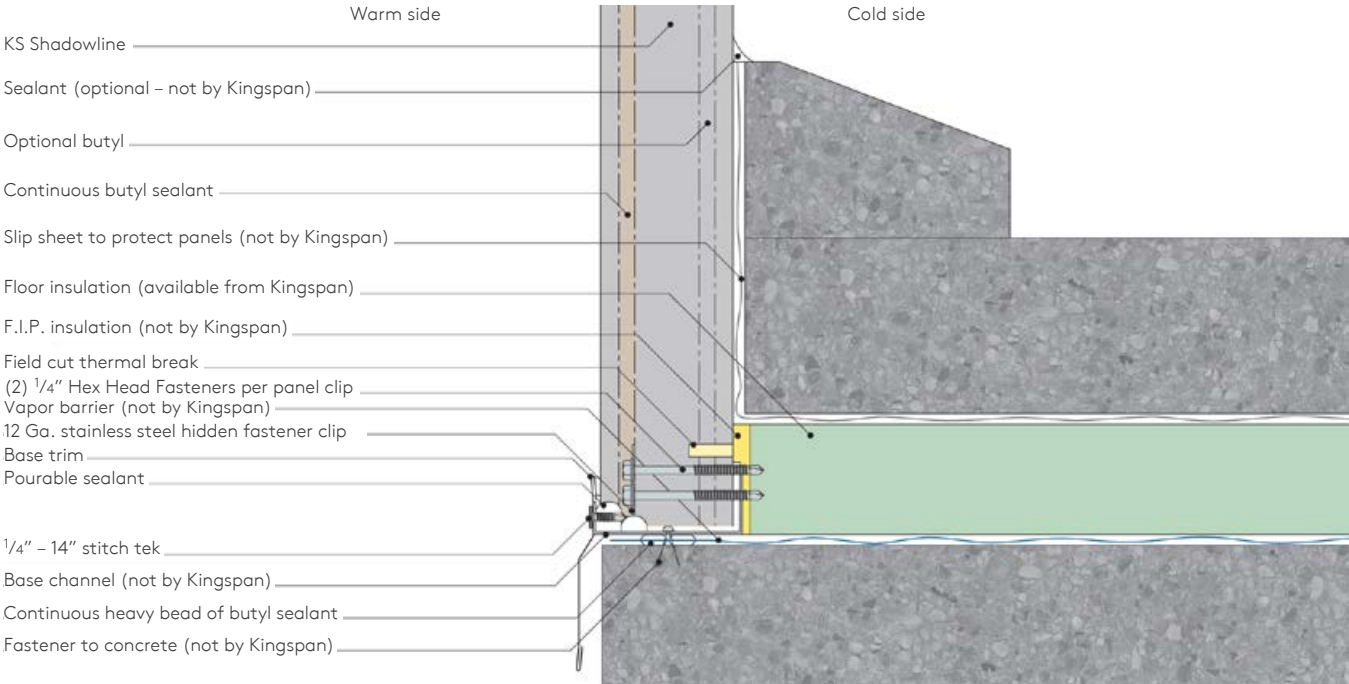

# Construction Details

## KS Shadowline Partition Base

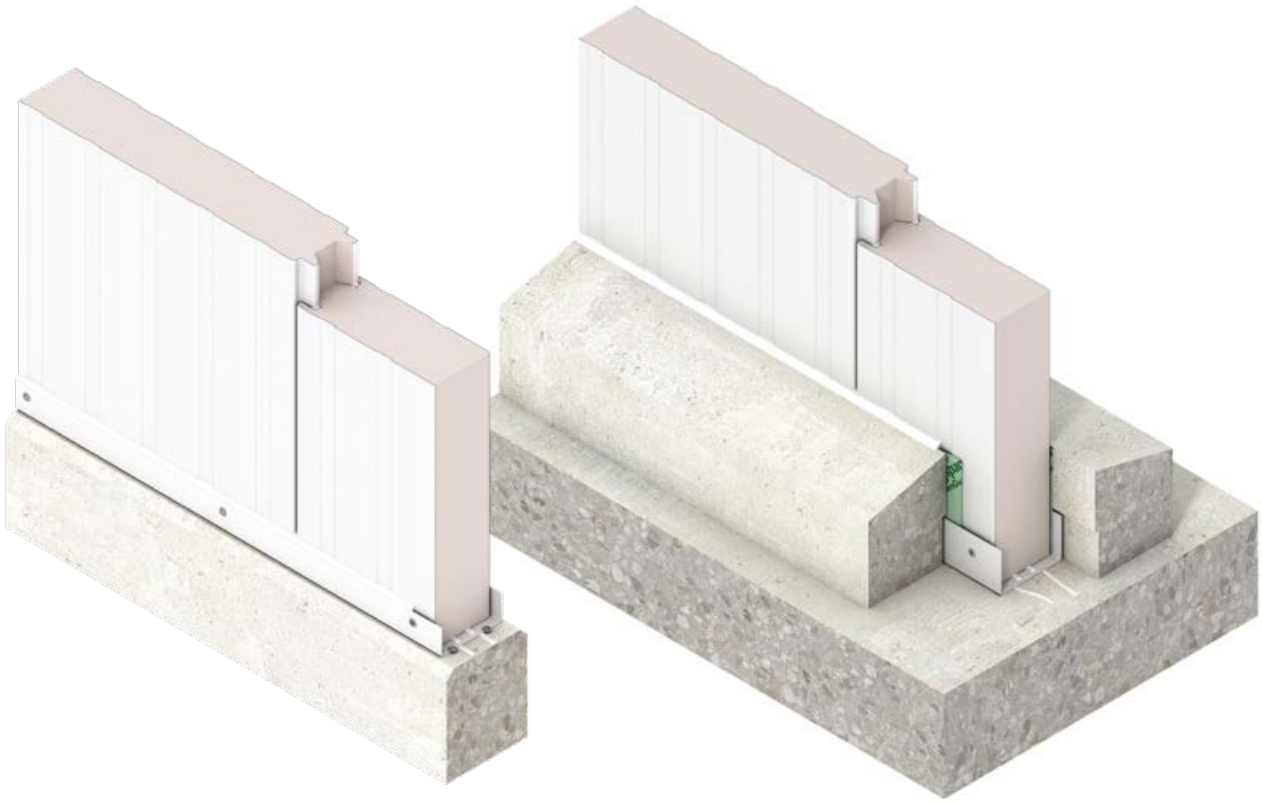

### On top of curbs

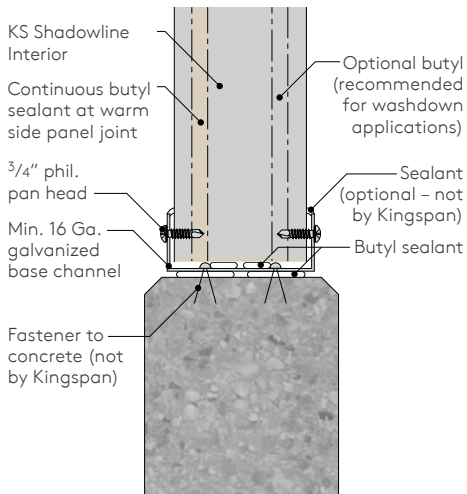

### With curbs

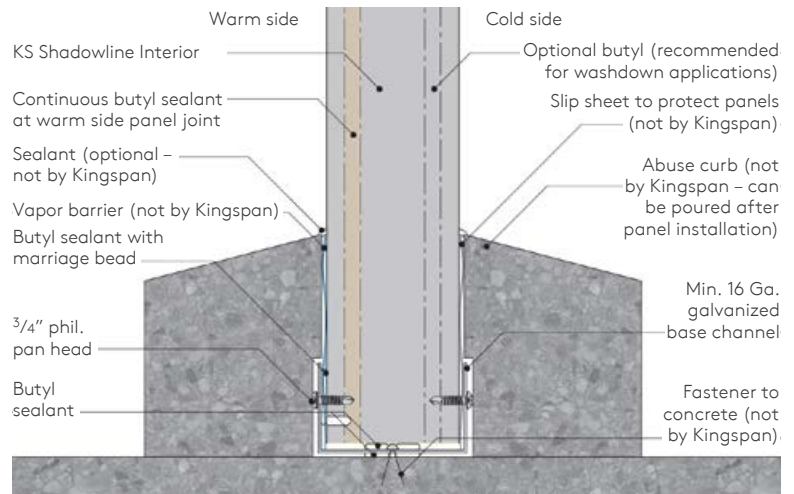



# Construction Details

KS Shadowline Partition Base

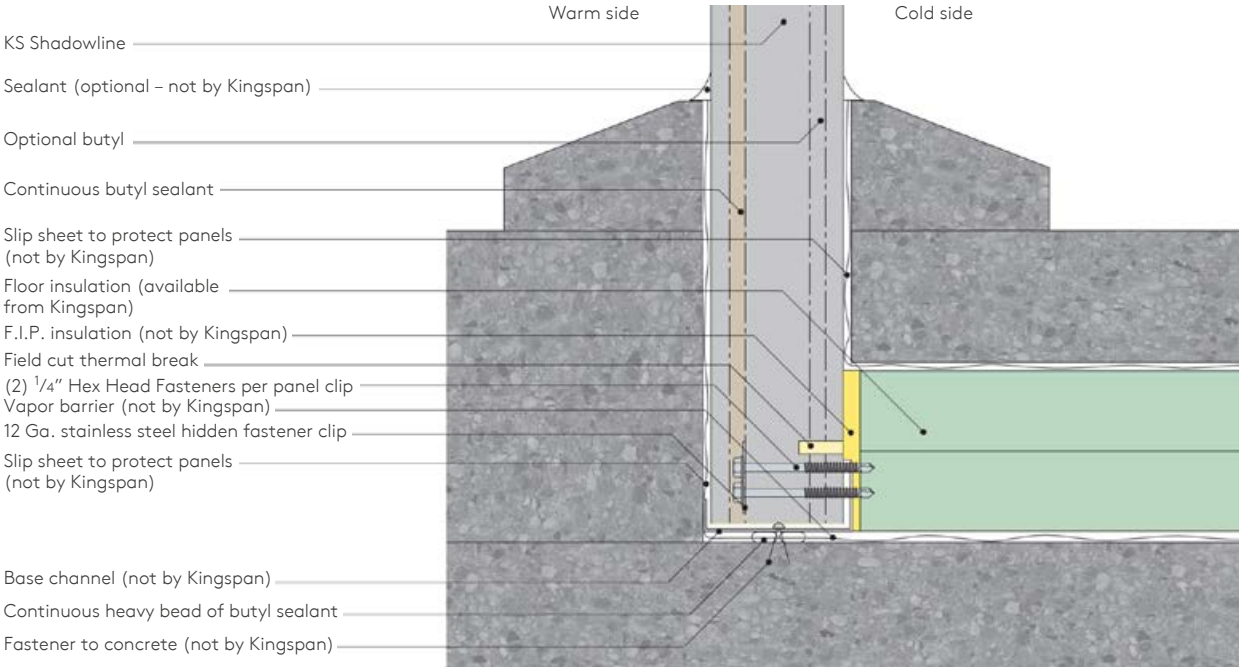
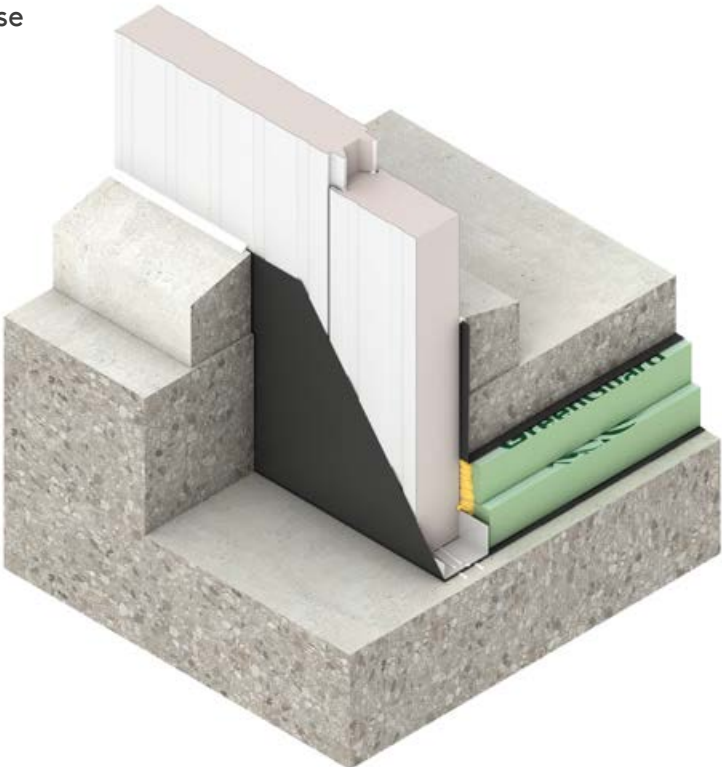

# Construction Details

## KS Shadowline Outside Corner Flush Trim

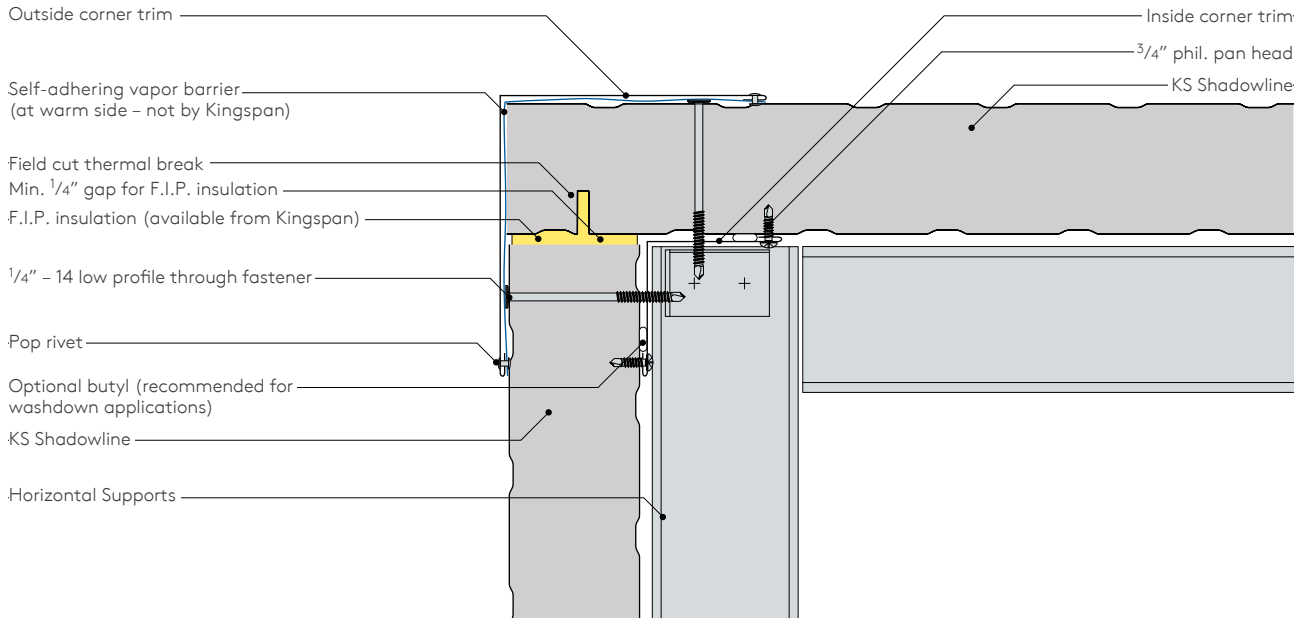
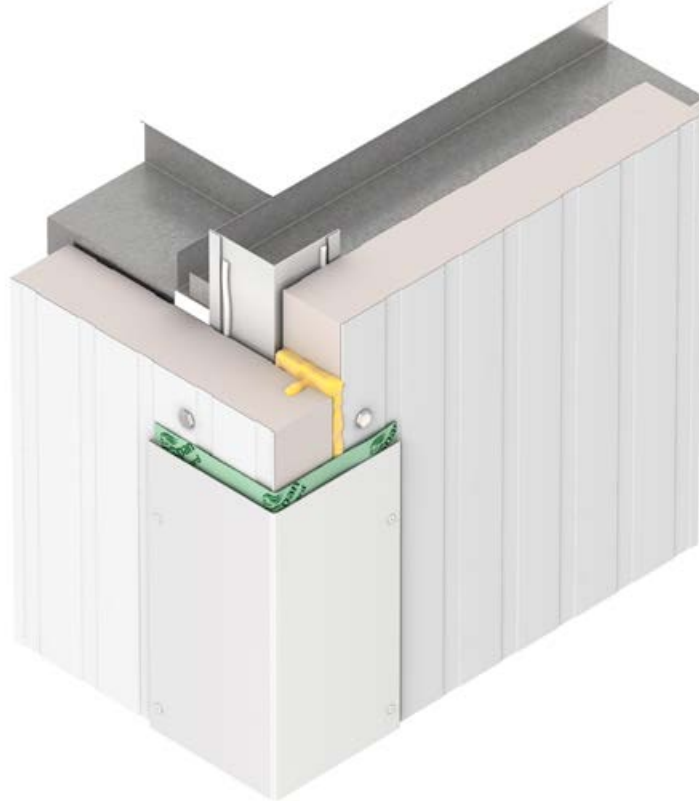

# Construction Details

## KS Shadowline Inside Corner Flush Trim

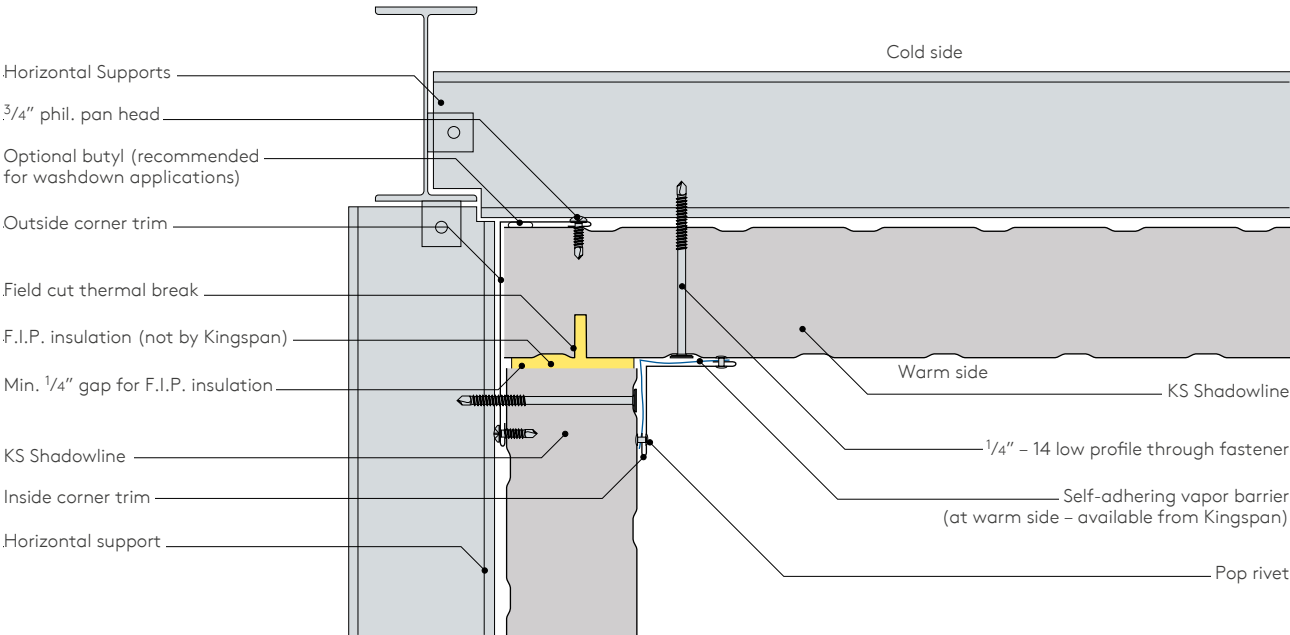
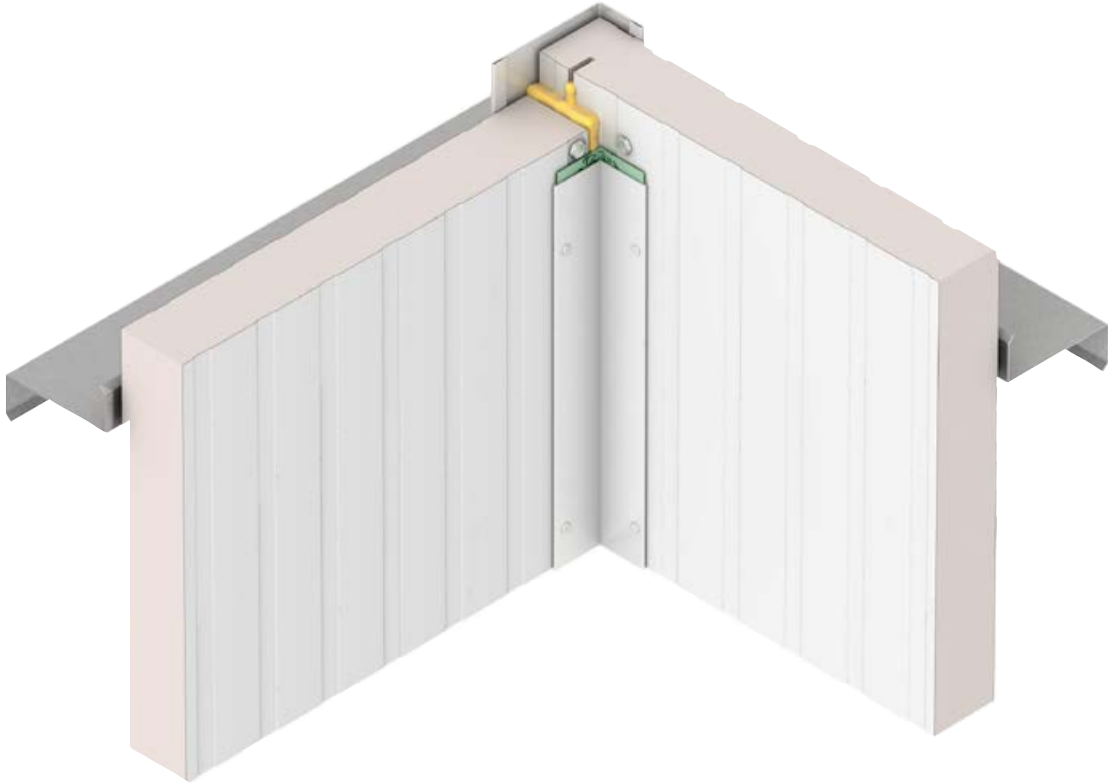

# Construction Details

## KS Shadowline Interior Partition to Exterior Wall

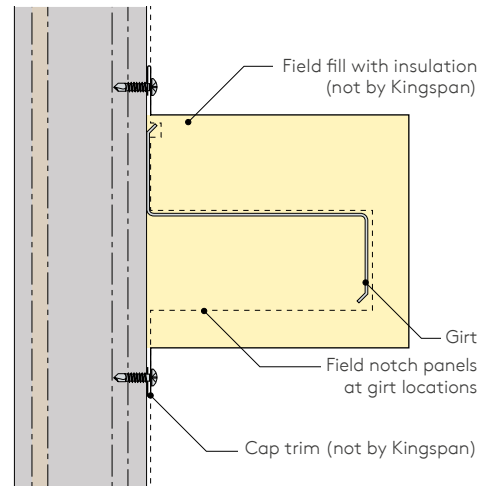
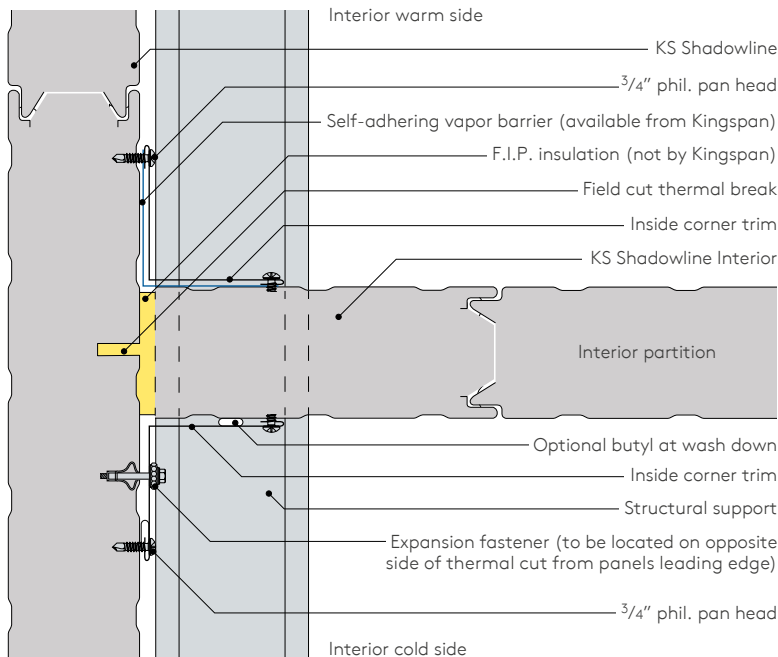
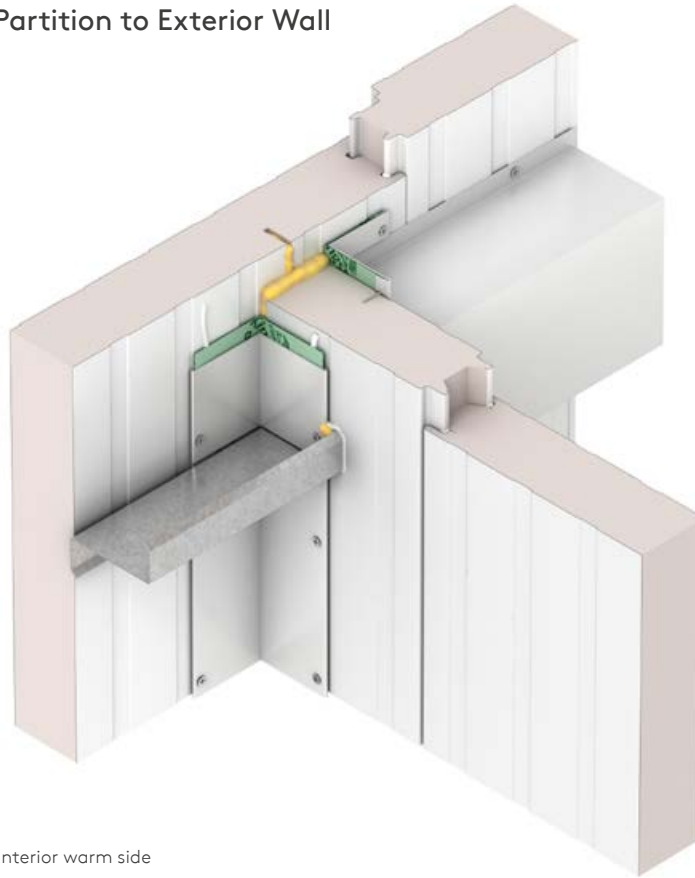

# Construction Details

## KS Shadowline Rake with Membrane Roof

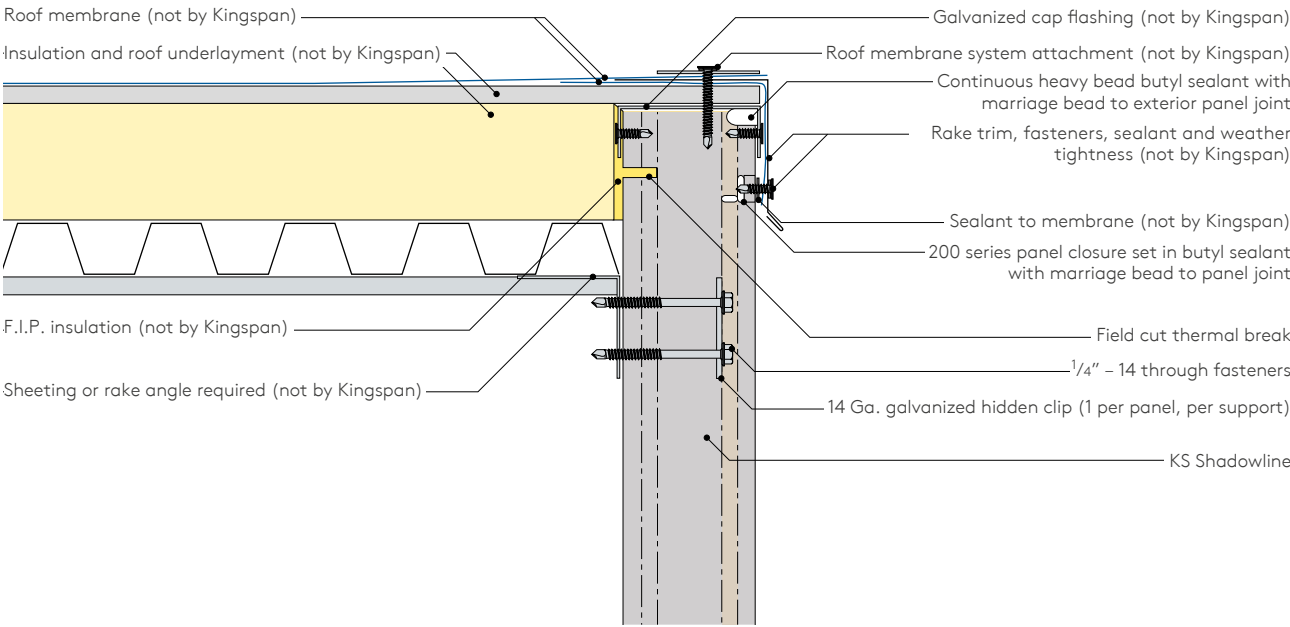
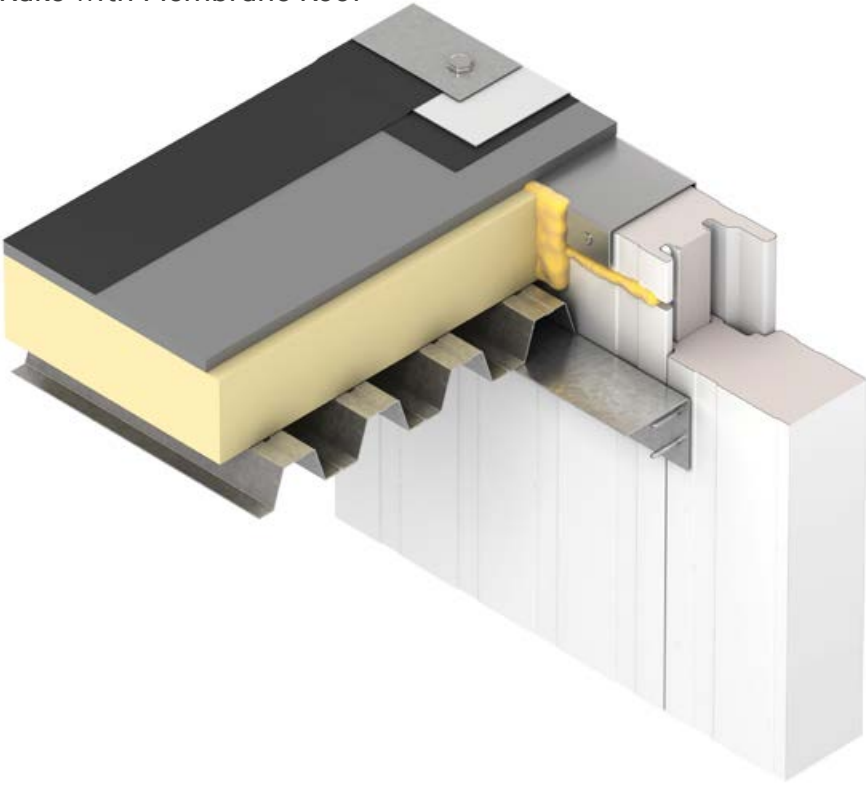

# Construction Details

## KS Shadowline Interior Wall to Ceiling Intersection

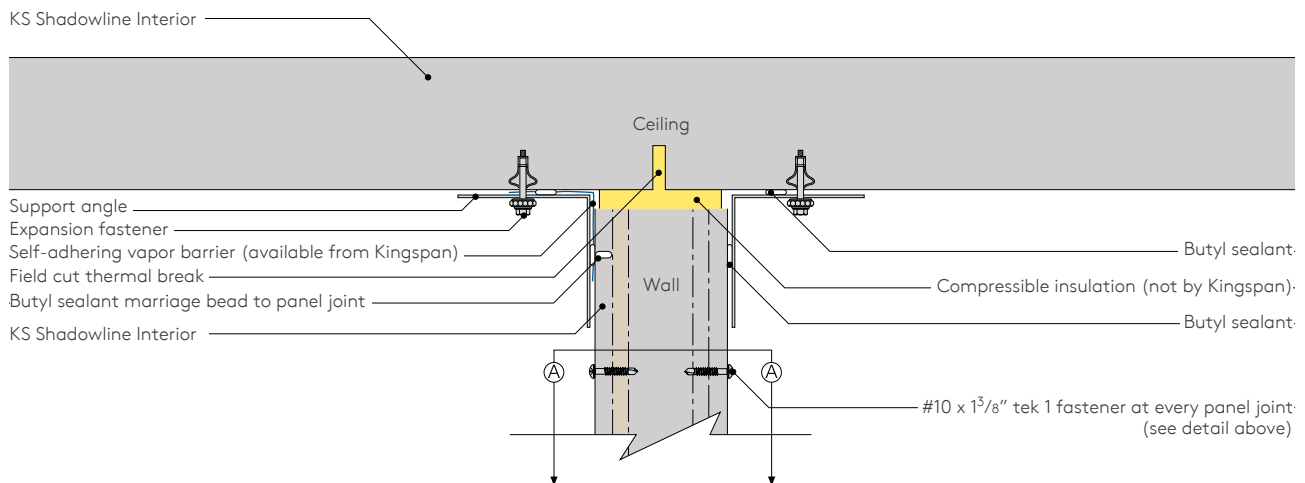
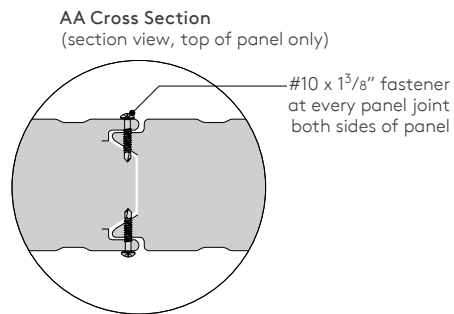

# Construction Details

## KS Shadowline Interior Ceiling Tee

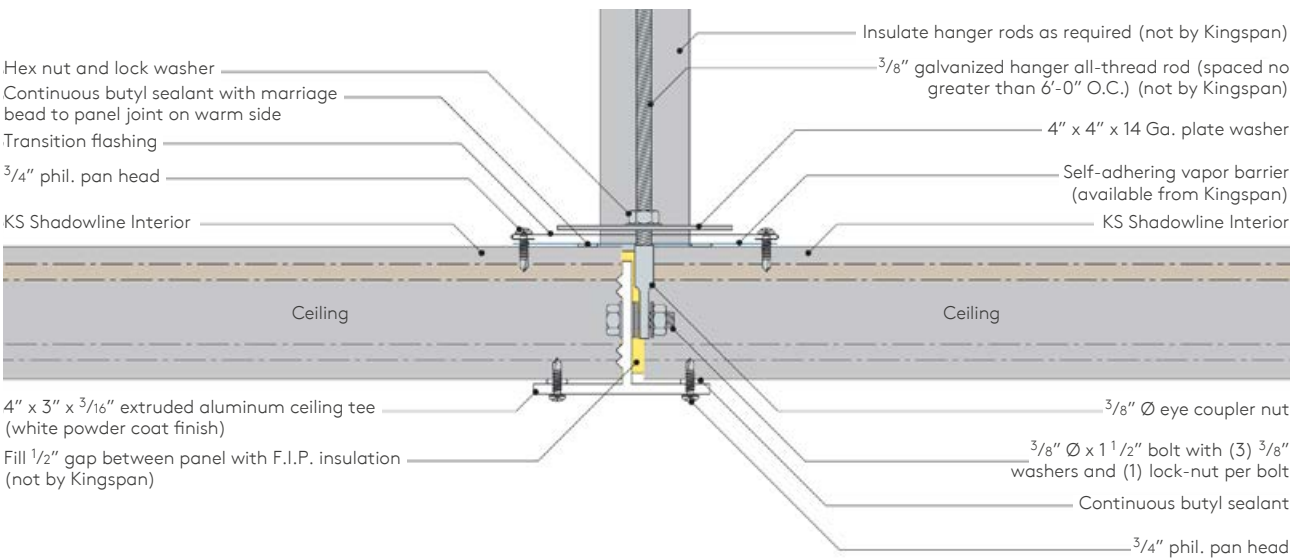
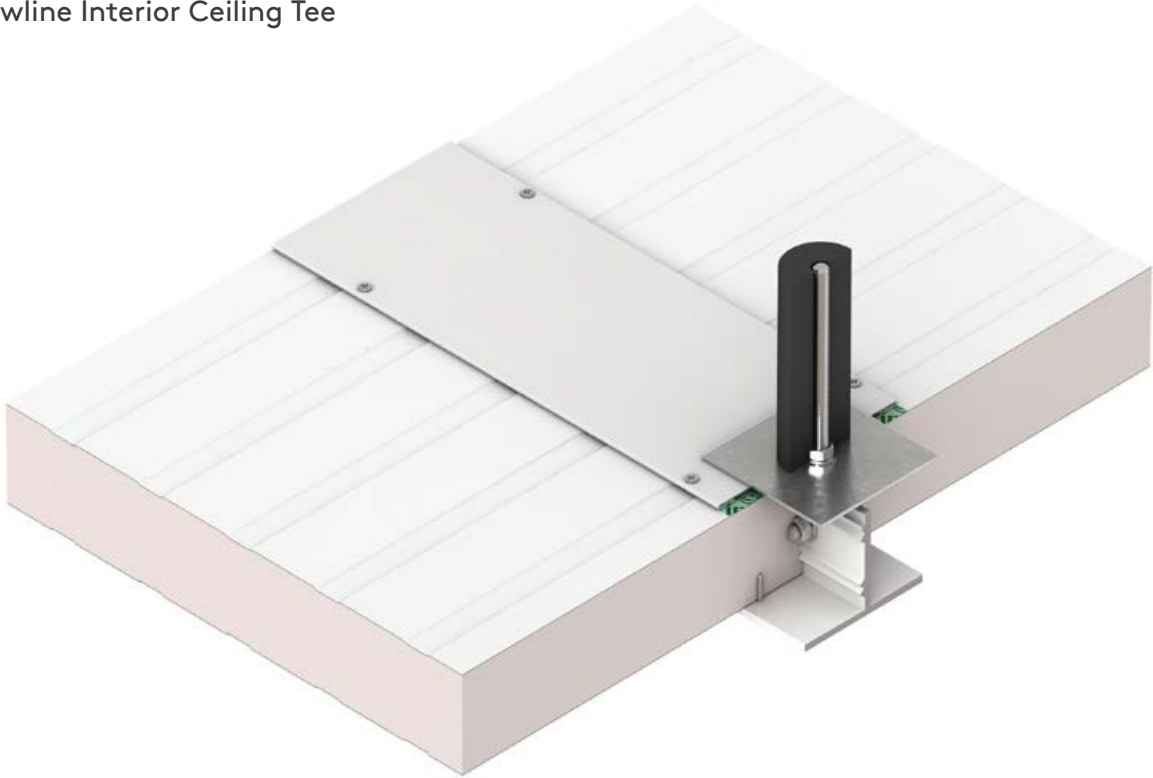

# Construction Details

## KS Shadowline Ceiling Hidden Clip Wall to Roof

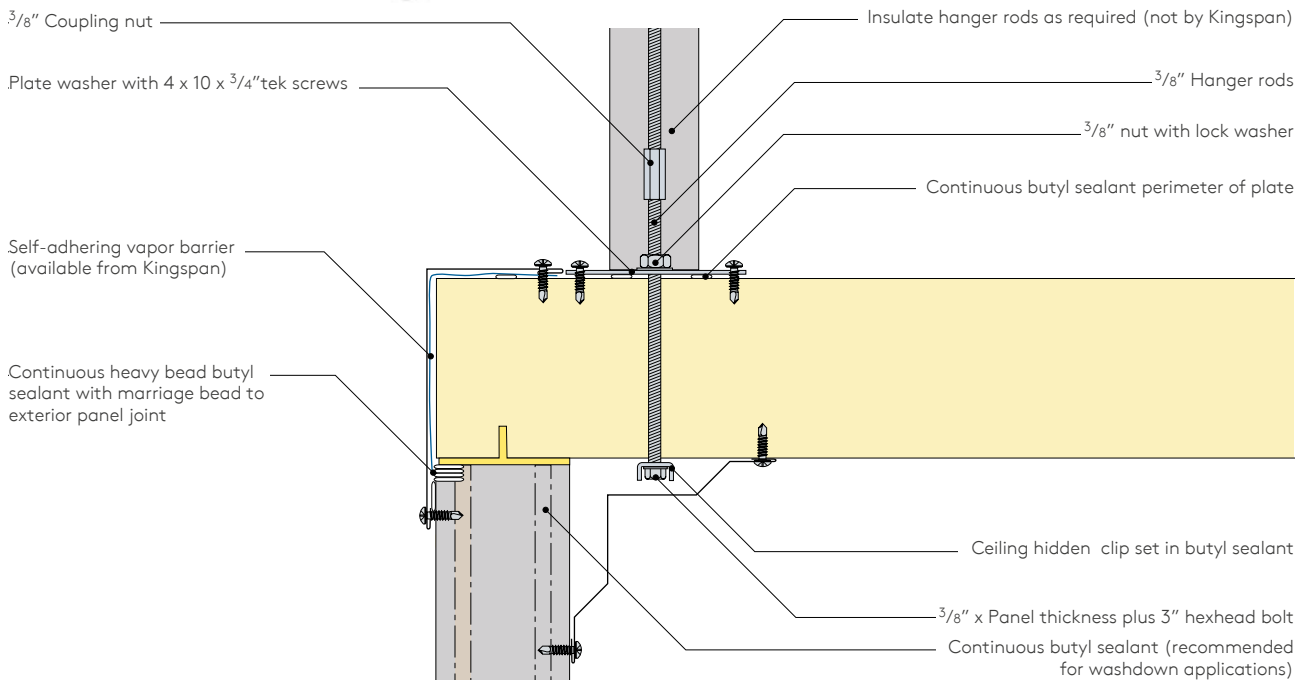
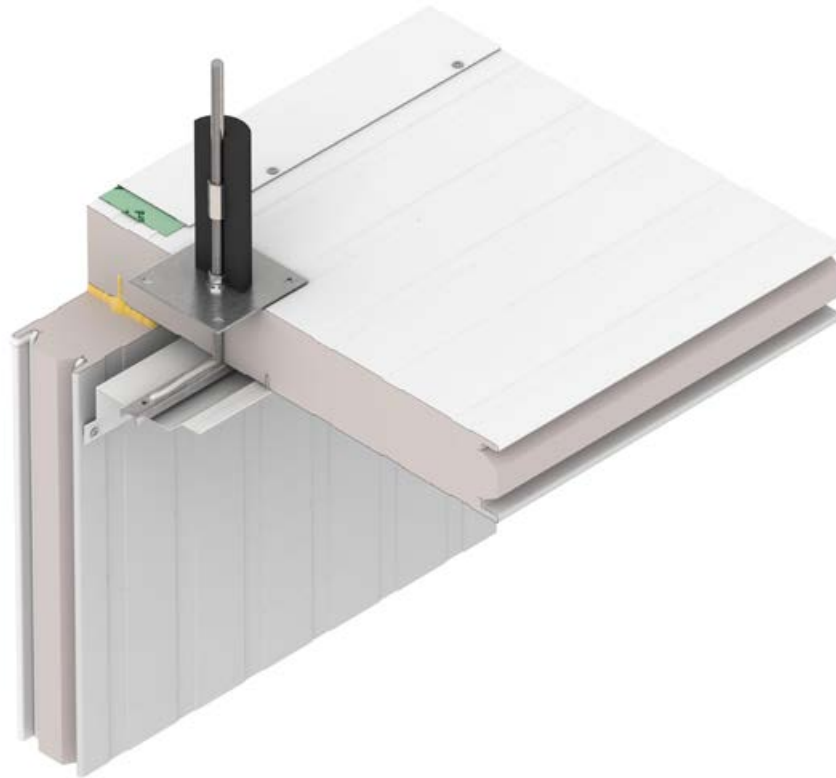



# Construction Details

## KS Shadowline Ceiling to all Longitudinal

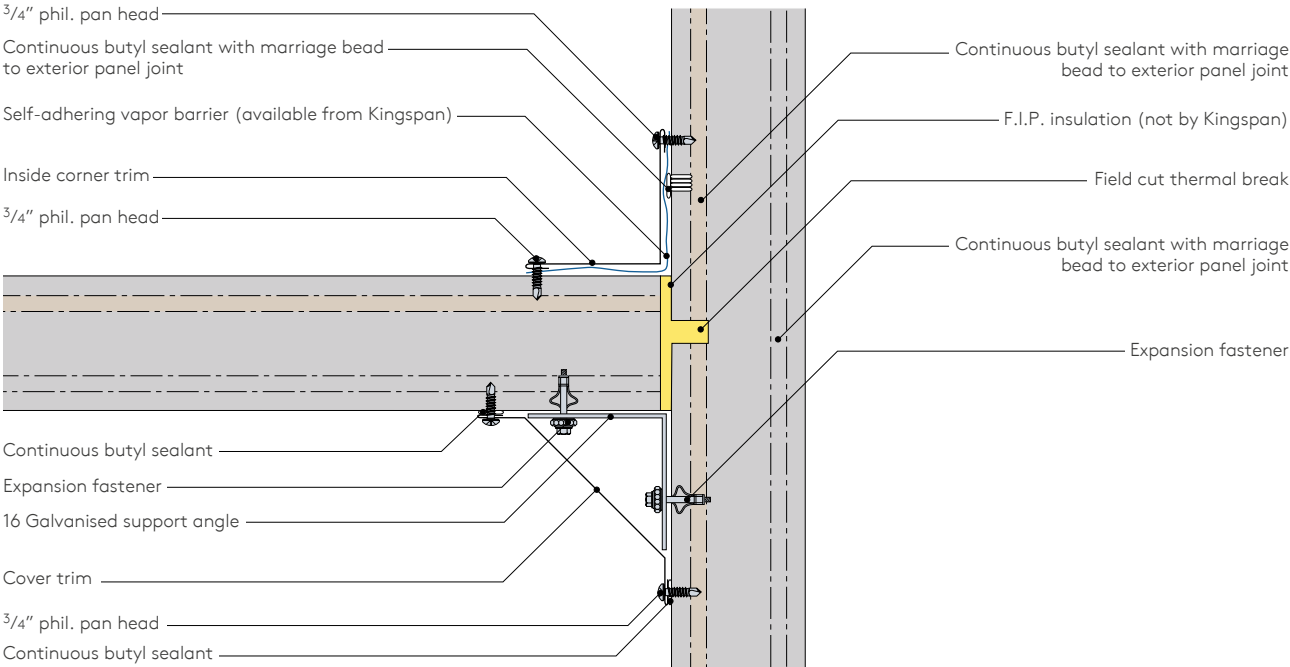

# Construction Details

## KS Shadowline Ceiling to Wall Transverse

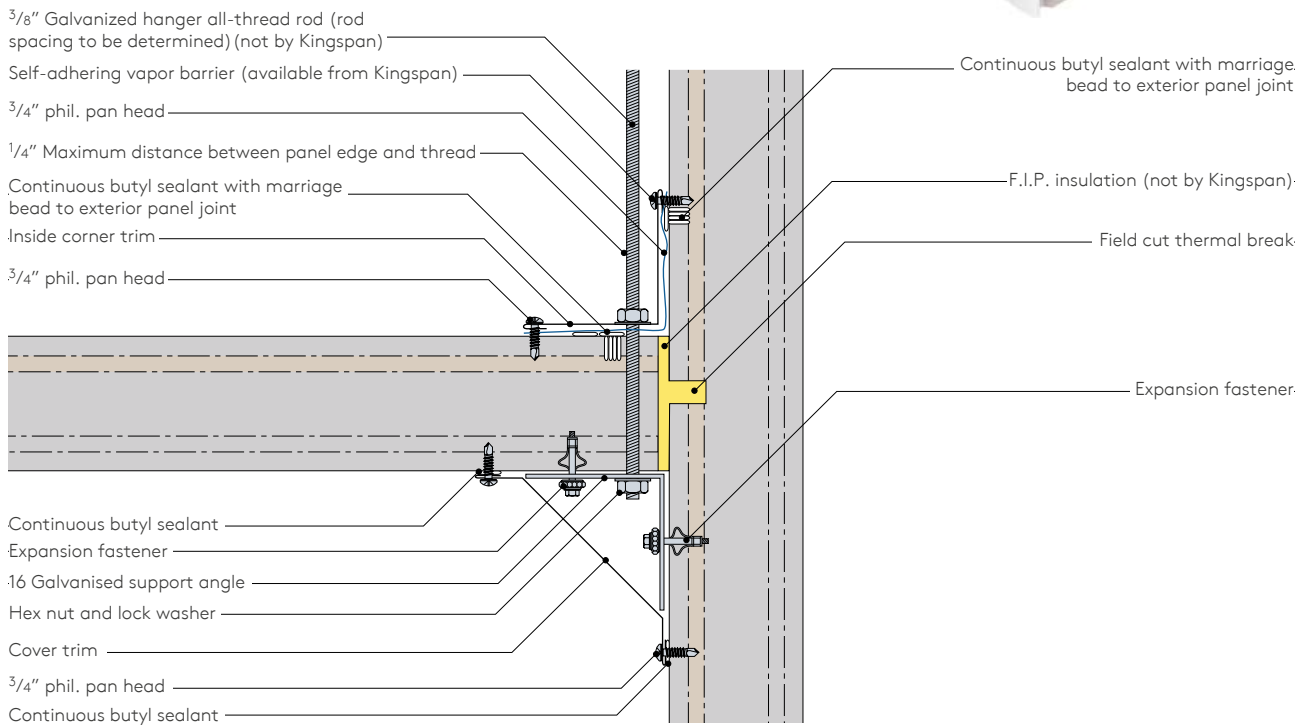
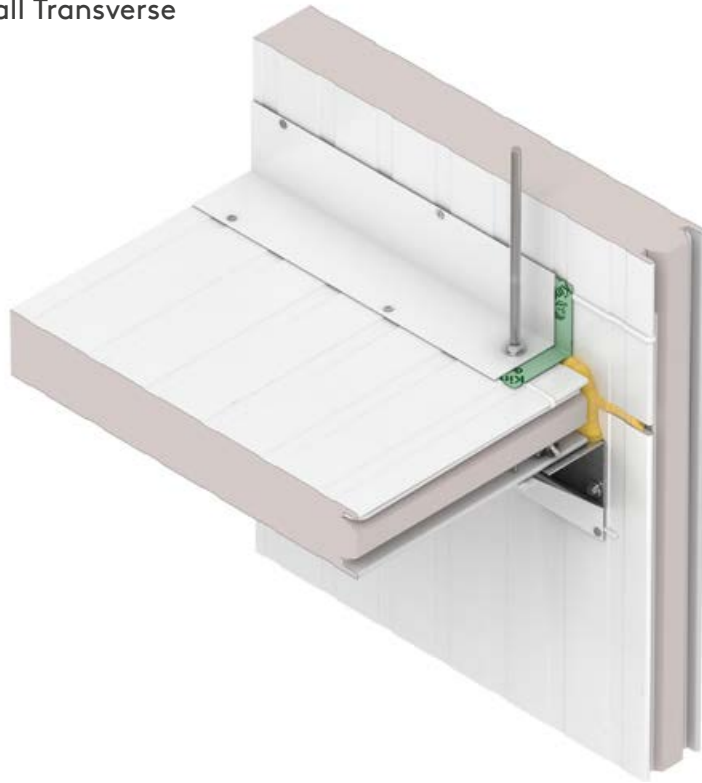

# Supplementary Products

## Our Insulation Board Offerings



### XPS Type IV 30 psi Board

Kingspan GreenGuard Type IV 30 psi Insulation Board comprises 1" to 3" thick closed-cell polystyrene (XPS) with a minimum compressive strength of 30 psi. It has high water resistance and an R-value of 5.0 per inch of thickness. It is available in a square edge board, ship-lap edge board or score-board. XPS insulation is lightweight, easy to handle, and easy to cut with a knife. It meets and exceeds all Type IV and Type X specifications.

Suitable for normal loading situations, including Cold Storage floors.

### XPS Type VI 40 PSI Board

Type VI 40 PSI Insulation Board is designed for use in high load applications requiring compressive strength up to 40PSI. It meets ASTM C 578 Type VI requirements.

Designed for high load situations, like low-temperature freezer floor applications, and rack loaded cold storage facility floors.

### XPS Type VII 60 PSI Board

Insulation Board comprises closed-cell extruded polystyrene (XPS) with a minimum compressive strength of 60 psi. For use as insulation for high load-bearing engineered applications requiring 60 psi minimum compressive strength, ASRS High Rise Cold Storage facilities.



# Supplementary Products

---

## Controlled Environment Door Systems

---

Hercules® Cold Storage Doors has been a leader in the industry for over 64 years.

Our engineering staff has the capability to design doors to meet the specific design criteria of your projects. The proven performance and customer satisfaction of the Hercules® product line is worldwide. Hercules® specializes in custom designed door products for the cold storage, controlled environment, food and beverage processing / distribution, and pharmaceutical industries.

The Hercules® Door offers a complete line of specialty doors for your specific applications including Blast Freezer, Freezer, Cooler, Docks, Processing, Ripening Rooms, Automotive Test Cells, Research Facilities, and Distribution Facilities. With more than a dozen different designs, Hercules® has the door to suit your climate controlled needs.

For the complete cold storage building envelope, use Kingspan Insulated Wall and Roof panels along with Hercules® doors.

Our insulation material consists of foamed-in-place urethane modified isocyanurate, in thicknesses of 4" and 6" equating in R values as high as 49.

In an effort to continuously improve our services, please understand that we reserve the right to modify our products and details based on our professional review of each specific application. This ensures that the products you receive are truly premium quality.



TESTED & APPROVED



BUILDING  
CERTIFICATION &  
GREEN TARGETS



INDOOR  
ENVIRONMENTAL  
QUALITY



LIFE-CYCLED BENEFITS

# Supplementary Products

## Standard Product Line

We refer to these door models as 'standard' because they happen to be our most popular designs. They are basic operating designs, because every Hercules® Door is custom built. Adding custom features to suit specific applications or difficult locations is part of the individualized service we are proud to offer at Hercules® Doors.



### Vertical Lift Door

- Ideal for applications where there is minimum side room, or when several door openings are close together
- Suitable for drive-thru traffic in conjunction with forklifts and other freight transfer vehicles
- Available with electric or manual operation
- Double vertical lift door is also available if head room is limited to slightly more than half the door height

### Infitting / Overlap Hinged Door

- Designed for use in environmentally controlled buildings such as freezers and coolers where only hand truck and personnel movement is necessary
- Suitable for both interior and exterior applications
- Available as a two-panel or 'double' hinged door for larger openings

### Bi-Parting Horizontal Sliding Door

- Ideal for applications where fast opening and closing is important, especially in areas where material handling equipment such as forklifts and pallet jacks operate
- Suitable for coolers, freezers, warehouses and industrial buildings
- Available with electric or manual operation

### Horizontal Sliding Door

- Utilized for both pedestrian and material handling traffic, this design is perfectly suited for applications where space limitations restrict the use of swinging doors, or when installation space is available only on one side of the door opening
- Most suitable when opening speed is not of great importance
- Available with electric or manual operation





---

# Contact Details

---

## USA

DeLand | FL  
T: 877-638-3266

Modesto | CA  
T: 800-377-5110

E: [info.NA@kingspanpanels.com](mailto:info.NA@kingspanpanels.com)  
[www.kingspanpanels.us](http://www.kingspanpanels.us)

---

## Canada

Caledon | ON  
T: 866-442-3594

Langley | BC  
T: 877-937-6562

E: [info.NA@kingspanpanels.com](mailto:info.NA@kingspanpanels.com)  
[www.kingspanpanels.ca](http://www.kingspanpanels.ca)

For the product offering in other markets please contact your local sales representative or visit our website.

To ensure you are viewing the most recent and accurate product information, please visit [www.kingspanpanels.us](http://www.kingspanpanels.us) or [www.kingspanpanels.ca](http://www.kingspanpanels.ca).

Care has been taken to ensure that the contents of this publication are accurate, but Kingspan Limited and its subsidiary companies do not accept responsibility for errors or for information that is found to be misleading. Suggestions for, or description of, the end use or application of products or methods of working are for information only and Kingspan Limited and its subsidiaries accept no liability in respect thereof.

© Kingspan, QuadCore, KingRib, KingSeam and the Lion Device are Registered Trademarks of the Kingspan Group plc in the US, Canada and other countries.

™ Azteco is a Trademark of Kingspan Group plc.

© Kingspan Insulated Panels Inc.

